

CHIEF®

**DYNAMIC
MONITOR ARMS
PRODUCT
GUIDE**



Global strength

built on local knowledge

Legrand is the global specialist in electrical and digital building infrastructures. Innovation is the driving force behind its development.

With an increasing investment in research and development (circa 5% of sales) and more than 4,000 active patents, the Legrand Group is focused on maintaining a high rate of new product launches that present innovative solutions to the market.

CORPORATE SOCIAL RESPONSIBILITY

Legrand's CSR roadmap is a natural extension to the governance and sustainable development approach in which the company has been engaged for many years. The CSR roadmap firmly asserts Legrand's ongoing commitment to sustainable development.

Respect human rights and communities
Ensure health, safety and well-being
Develop skills
Promote equal opportunity and diversity



Provide sustainable solutions
Ensure sustainable procurement
Act ethically

Mitigate climate change
Innovate for the circular economy
Prevent pollution



LEGRAND'S POWER DISTRIBUTION BUSINESS UNIT

Legrand's power distribution business unit is the home of Electrak, a leading name in power distribution and lighting control solutions.

Electrak powertrack systems, floor boxes, grommets, desk modules and lighting control ranges are installed in high specification offices around the world.



Powering the home and office



UNDERFLOOR POWER

Electrak's powertrack system is perfect for supplying underfloor power in cavity floor installations. With minimal parts, push-fit assembly and a complementary range of floor boxes, this flexible, easy-to-install system can be reconfigured as office layouts evolve.



POWERTRACK



CAVITY FLOOR BOXES



WORKPLACE POWER

Electrak's access grommets provide the gateway for power to feed from the underfloor powertrack network to the workstation, where all desk power requirements are met with our ranges of desk modules, Intersoc-R, on-desk and in-desk.



FLOOR GROMMETS



INTERSOC-R



ON-DESK AND IN-DESK



MODULAR MONITOR ARMS

The Chief brand offers a large and diverse selection of monitor arms. With both clamp and pole mount configurations, you can find a product that best adapts to your workspace. With different models and configurations, there is an option to suit any project requirement.

CHIEF[®]

KONTOUR™

Monitor arm solutions

KONTOUR™ MONITOR ARMS STYLE WITH STRENGTH AND FLEXIBILITY

The Kontour™ K1D dynamic height-adjustable desk clamp monitor arms are the perfect solution for offices, healthcare facilities or home.

BEST-IN-CLASS WEIGHT CAPACITY RANGE
MAKES SPECIFICATION SIMPLE



Create efficient, ergonomic workspaces that improve employee wellness and increase productivity. Single and multiple monitor mounts are available.

- **Patented Centris™ tilt** provides +75° to -10° of effortless tilt
- **Quick-release monitor interface** for ease of install and service, with 100 x 100 mm and 75 x 75 mm VESA compatibility
- 330 mm of **dynamic height adjustment**
- Simple **three-step installation**
- Sleek, solidly-constructed forged **aluminium arms**
- **Fast installation** and quick-release monitor for easy mounting

KEY FEATURES OF THE RANGE

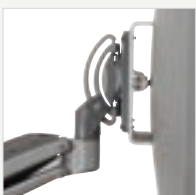

Quick-release monitor interface



Centris™ extreme tilt



Integrated cable management



Weight capacity adjustment

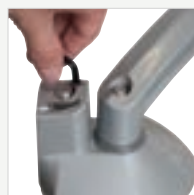

Integrated tool storage



Easily clamps to edge of desk or grommet hole

Kontour™ monitor arms

single and dual

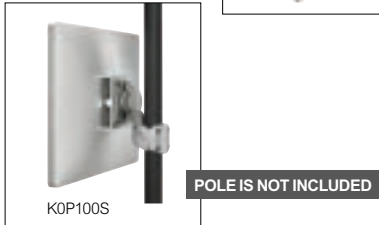

Pack	Cat. Nos.	Kontour™ monitor arms
1	K1D120W	<p>Tested to meet or exceed ANSI/BIFMA X5-5 desk & table products standard</p> <p>Monitor configuration – single or dual</p> <p>Minimum depth – 4" (103 mm)</p> <p>Maximum extension – 22" (551 mm)</p> <p>Suitable for typical monitor sizes up to 30" (762 mm)</p> <p>Colours – available in :</p> <ul style="list-style-type: none"> • Single and dual monitor arms - white and black • Pole mounts - silver and black <p>Type – gas / spring (not for Pole mount)</p> <p>Single monitor arm</p> <ul style="list-style-type: none"> ○ White ● Black
1	K1D120B	
1	K1D220W	<p>Dual monitor arm</p> <ul style="list-style-type: none"> ○ White ● Black
1	K1D220B	
1	K0P100S	<p>Pole mount</p> <ul style="list-style-type: none"> ● Silver ● Black
1	K0P100B	

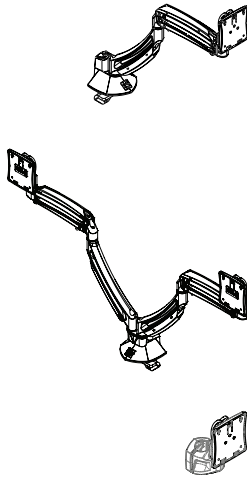

Kontour™ monitor arms

single and dual – technical information

Kontour™ monitor arms

Single monitor arm – Cat. No. K1D120

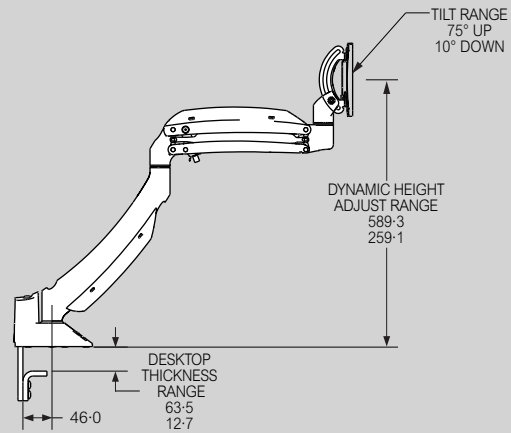

Dual monitor arm mount – Cat. No. K1D220

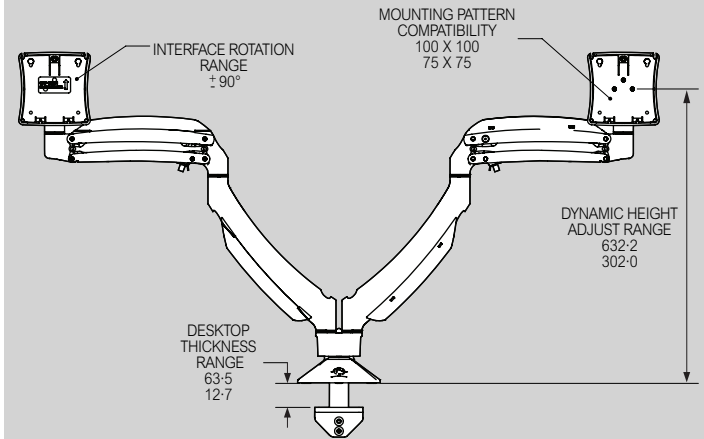

Pole mount – Cat. No. K0P100

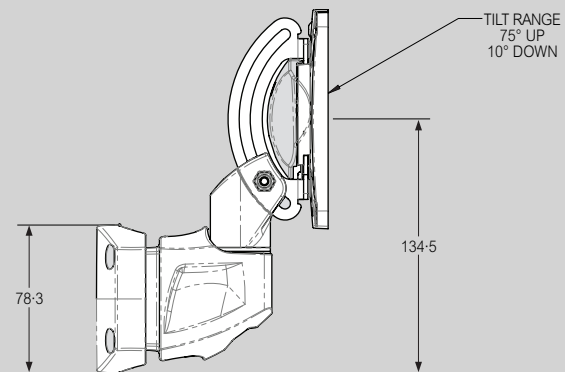

All dimensions (mm) are nominal



KONCIS™

Monitor arm solutions

KONCIS™ MONITOR ARMS EFFORTLESS WORKSPACE SOLUTIONS

The Koncis™ range of dynamic monitor arms provide simple workspace solutions designed to support modern monitors, enhancing ergonomics and productivity.

The range features a refined design that compliments Legrand's Electrak desktop products, offering a complete workstation power solution.

DESIGNED TO
MEET THE NEEDS
OF THE HOME
AND OFFICE



- **Patented Centris™ tilt** provides +75° to -10° of effortless tilt
- **Quick-release monitor interface** for ease of install and service, with 100 x 100 mm and 75 x 75 mm VESA compatibility
- 330 mm of **dynamic height adjustment**
- **Single and dual arms** provide 0.9 to 6.8 kg weight capacity per monitor, supporting most monitors up to 32" - diagonal
- **Integrated cable management** provides a simple and elegant installation
- **Pre-installed 180° rotation stop** protects walls and furniture panels (removable)
- **55 cm maximum arm extension**, 10 cm minimum depth
- **Fast installation** and quick-release monitor for easy mounting

KEY FEATURES OF THE RANGE



Quick-release monitor interface



Centris™ extreme tilt

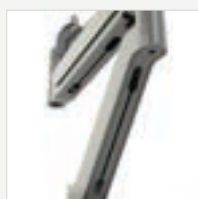

Integrated cable management

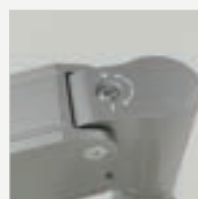

Weight capacity adjustment



Integrated tool storage



Flexible desk clamp base

Koncis™ monitor arms

single and dual



Pack	Cat. Nos.	Koncis™ monitor arms
1	DMA1S	Tested to meet or exceed ANSI/BIFMA X5-5 desk & table products standard Monitor configuration – single or dual Minimum depth – 4" (103 mm) Maximum extension – 22" (551 mm) Suitable for typical monitor sizes up to 32" (812 mm) Colours – available in silver and black Type – gas Single monitor arm ● Silver ● Black
1	DMA1B	
1	DMA2S	Dual monitor arm ● Silver ● Black
1	DMA2B	

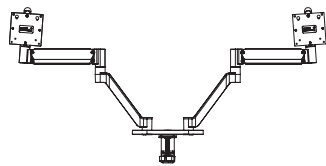
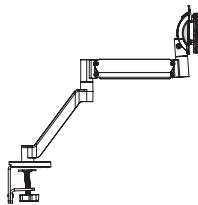

Koncis™ monitor arms

single and dual – technical information

Koncis™ monitor arms

Single monitor arm – Cat. No. DMA1

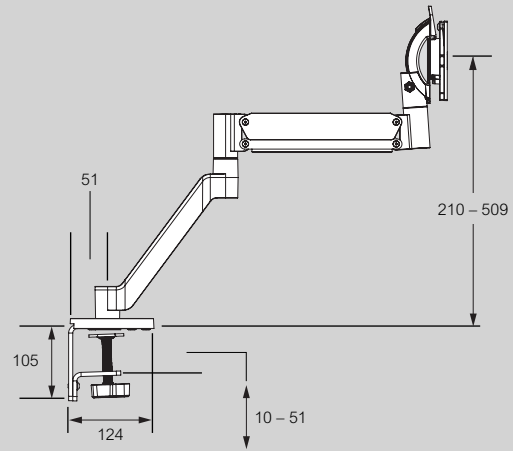

Dual monitor arm – Cat. No. DMA2

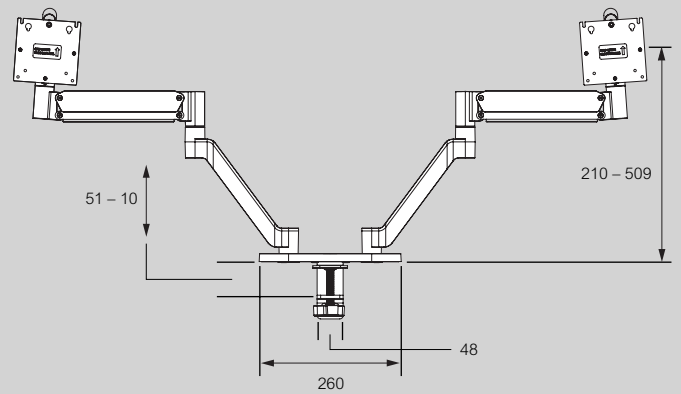

All dimensions (mm) are nominal

CONTACT DETAILS

Quotations and Technical Support:

Legrand Electric Ltd.
Great King Street North,
Birmingham, B19 2LF
Tel: +44 (0) 370 608 9020
E-mail: powersales.uk@legrand.co.uk

Customer Services:

Legrand Electric Ltd.
Dial Lane, West Bromwich,
B70 0EB
Tel: +44 (0) 345 605 4333
E-mail: legrand.sales@legrand.co.uk

Republic of Ireland:

Tel: 01 295 9673
E-mail: legrand.sales@legrand.co.uk



FOLLOW US AT

- @ www.legrand.co.uk
www.legrand.ie
-  www.youtube.com/legrandtvuk
-  www.voltimum.co.uk
www.voltimum.ie
-  www.twitter.com/legranduk
-  [www.linkedin.com/
company/legranduk](http://www.linkedin.com/company/legranduk)



Head office (UK and Ireland):

Legrand Electric Limited
Great King Street North, Birmingham, B19 2LF
Tel: +44 (0) 370 608 9000 Fax: +44 (0) 370 608 9004
Website: www.legrand.co.uk

In accordance with its policy of continuous improvement, the Company reserves the right to change specifications and designs without notice. All illustrations, descriptions, dimensions and weights in this catalogue are for guidance and cannot be held binding on the Company. All contents and design presentation included in this publication are © Legrand Electric Limited. All rights reserved. 2021.



This document is printed on sustainably sourced paper. Please recycle.

The Legrand logo is a registered trademark of the Legrand group of companies.