

Storage, installation and user manual for SCP09 busbar systems

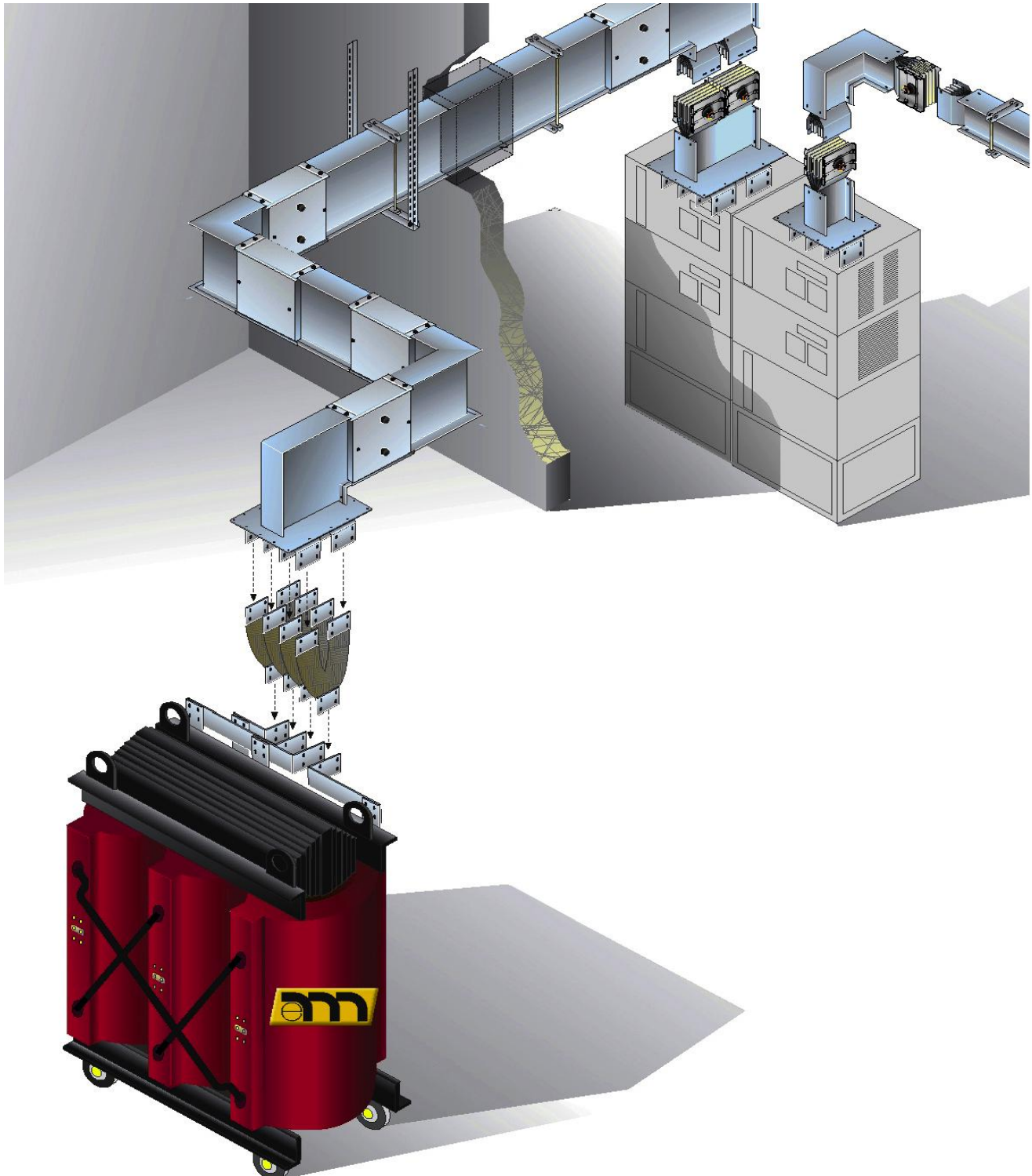

BTicino S.p.A. reserves the right to modify and improve its products without notice, following the continuous production, technological, and regulatory adaptation process.



BUSBAR TRUNKING SYSTEMS

WARNINGS	Page 3
HANDLING	Page 4
GOODS RECEPTION	Page 10
STORAGE	Page 11
INSTALLATION	Page 12
CHECKS TO BE CARRIED OUT DURING INSTALLATION	Page 16
CHECKS TO BE CARRIED OUT AFTER COMPLETING THE INSTALLATION	Page 19
REGULAR CHECKS	Page 20

These instructions are provided to ensure appropriate storage, correct installation, and efficient use of the system.

Note: carefully read these instructions upon receipt of the material and before installing the system, and putting it into operation.

The installation must be completed by competent and suitably trained personnel, as prescribed by CEI 11-27 and 50110-1:2004-11 (CEI 11-48) standards, corresponding international standards, or specific applicable standards of the individual countries of installation.

In order to guarantee the safety of personnel, the installation activities must only be carried out with the power voltage disconnected, unless otherwise stated.

WARNING

When working with electric systems, pay particular attention to the risk of electric shock. Electric shocks can cause serious injury, or even death.

NOTE: Do not tamper with products manufactured by BTicino S.p.A., or perform modifications without written authorisation by BTicino S.p.A. BTicino S.p.A. does not authorise any kinds of repairs. All tampering, or modifications not authorised in writing by BTicino S.p.A. will void the product warranty.

When handling the material comply with the regulations for safety in the workplace pursuant Leg. Decree No. 81 dated 09/04/2008 (Consolidated act on safety in the workplace).

Follow the indications supplied to prevent damage to materials, or risks to personnel.

Below are the instructions to follow for the correct handling of the materials.

- 1** Always pay the utmost attention when opening packages.
- 2** To open wooden cases in which the materials are dispatched to protect them use a claw hammer.
- 3** Handle the busbars with due care and attention. Do not subject busbars to torsions, dents, violent impact, or sharp movements that may damage their internal components.
- 4** Do not lift the busbars from their ends. This could not just damage the busbar, but also cause injury to the personnel carrying out the operation. When using a crane to install the busbar, use nylon slings to balance the weight.
- 5** Do not use belts or other systems to lift them to the junction windows, or the expansion cap. This may damage the busbars.
- 6** When not installing the busbar immediately upon receipt, ensure appropriate storage for the time required before installation, following the storage instructions.
- 7** Do not drag the busbar along the floor. This could cause irreversible damage.
- 8** To correctly move busbars, cranes may be used. These would enable to lift the busbars from the floor very easily.
- 9** Do not move already assembled busbars, as this would cause stress at the point of the electric joint.

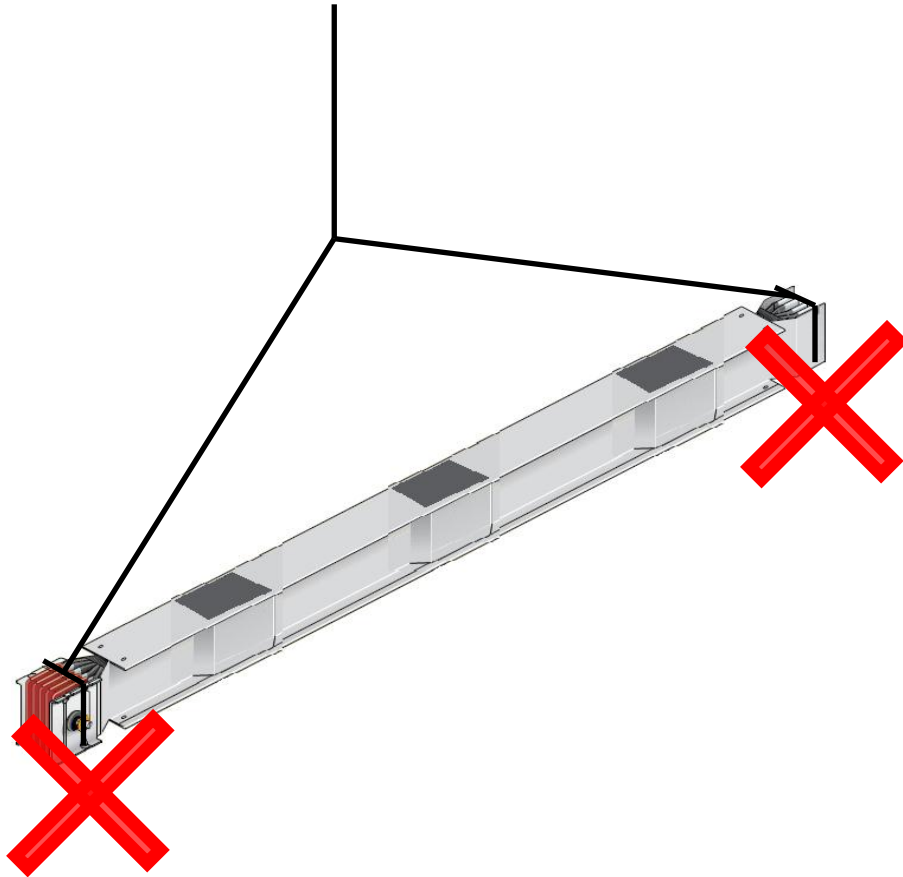

Fig. 1

Do not lift the busbars from their ends.

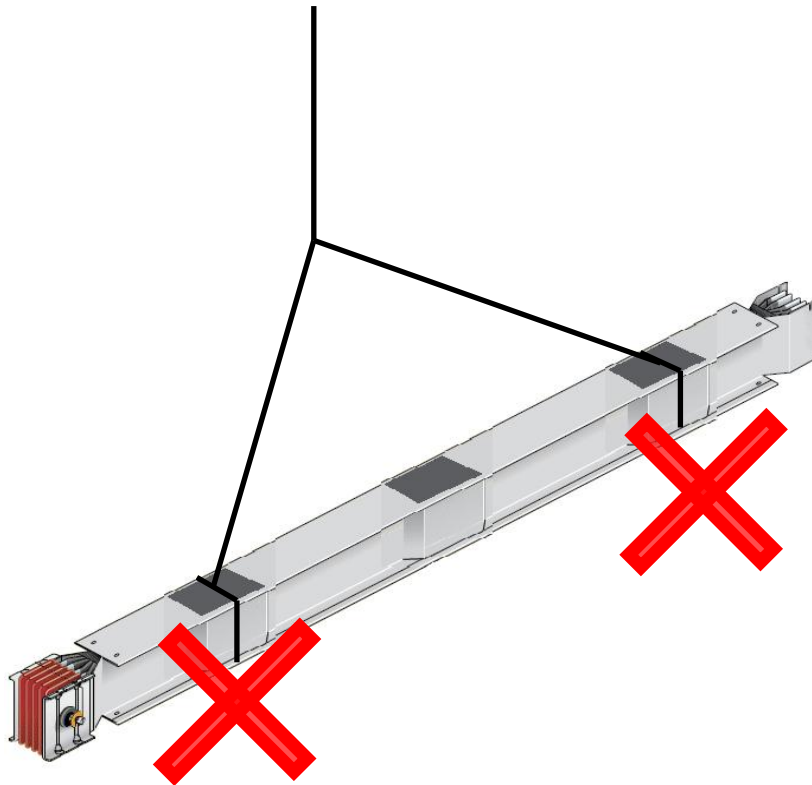

Fig. 2

Do not use belts or other systems to lift them to the junction windows.

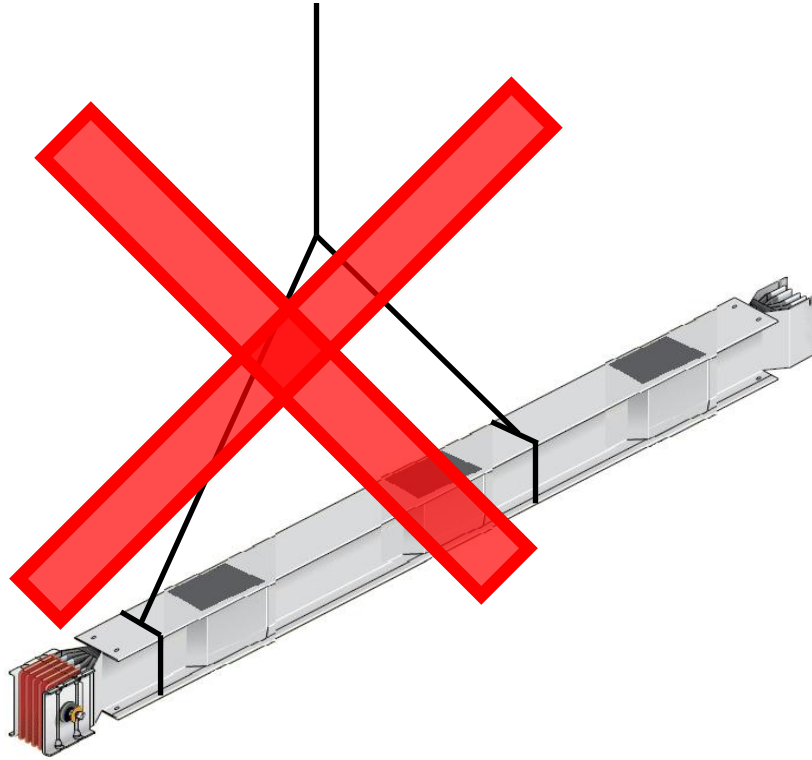

Fig. 3

Do not use belts or other systems to lift the busbars in unbalanced positions.

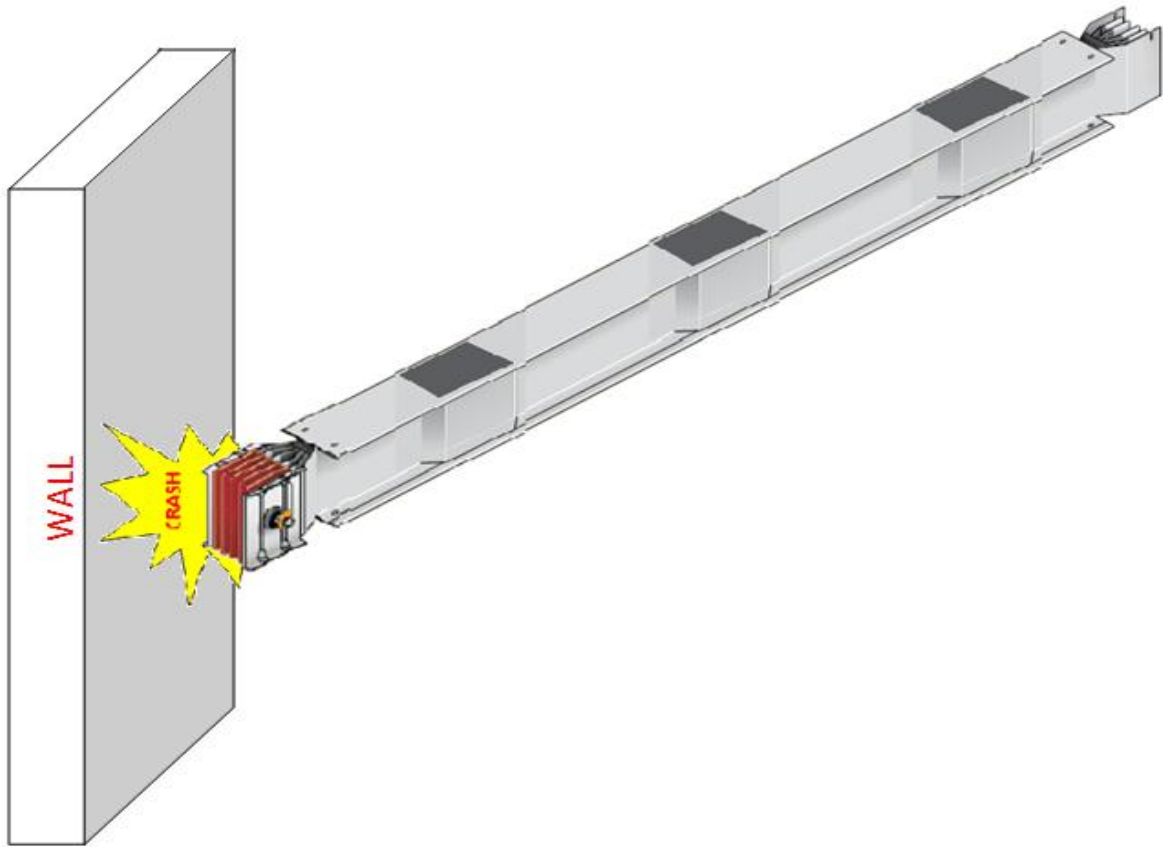

Fig. 4

Handle the busbars with due care and attention. Do not subject busbars to torsions, dents, violent impact, or sharp movements that may damage their internal components.

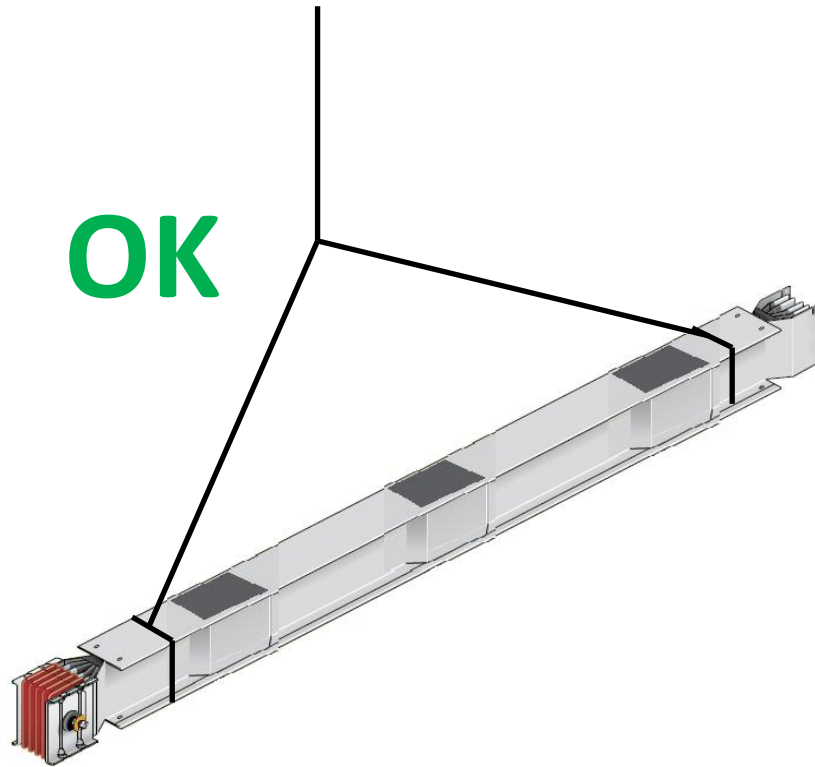

Fig. 5

Correct way of lifting the busbar.

Upon receipt of the goods check the following:

- 1** integrity of the packaging, and the goods, if delivered in a see-through package
- 2** consistency of the material with the Delivery Note and the packing list, if supplied

- 3** consistency of the material with the order acknowledgement details

In case of problems, please contact Legrand Technical Support or your local Legrand Sales Representative.

Below are the instructions to follow for correct storage of the materials.

Failure to comply with the indications supplied may cause damage to the materials, and make the product warranties void.

Store the material in a dry place, protected from weather conditions, rain and humidity, to prevent the formation of condensation inside the busbars.

Also ensure that the busbars are protected from soil, mud, dust, or dirt in general, smoke, water. Position the material in a way that protects it from physical damage. We recommend that busbars are not stored outside.

It is recommended that the material is stored indoor, in a dry location. If storing the busbars outside for short-medium periods, ensure that it is appropriately protected, to avoid accidental infiltration of water, which will result in them being damaged.

The material can be transported and stored at a temperature between -25°C and +55°C.

Before installation, all material should be inspected for damage.

When installing the busbars comply with the following:

- 1** do not position the busbars near pipes containing liquids.
- 2** for the installation only use bracketing systems supplied by BTicino, and follow the instructions found in the catalogue
- 3** only use accessories supplied by BTicino
- 4** check that the operating voltage coincides with that indicated on the product plate.
- 5** check that the system operating current does not exceed the product rated current, downgrading it if required
- 6** check if the busbar capacity must be downgraded (for example due to high ambient temperature, presence of harmonics, etc.)
- 7** do not install the standard product in particular environments (high concentration of chlorine, explosive atmosphere, etc.).
- 8** for outdoor installations, protect the busbar with a protection canopy. The IP55 protection degree can be affected by unsuitably protected outdoor installation.

To connect two elements follow the procedure shown in figure 6.

This illustration can also be found on all straight pieces.

To ensure a correct installation remember that:

- 1** the preinstalled monobloc must not be disassembled
- 2** pay attention to the position of the neutral
- 3** The monobloc pin must fit the recess in the metal sheet of the element to connect
- 4** insert the monobloc slipping it from the top
- 5** use the joint cap supplied separately to position the elements at the correct distance
- 6** tighten the monobloc
- 7** the securing of the monobloc does not require a torque wrench, as correct torque is ensured by a self-piercing nuts, which will break when this is reached.
- 8** secure both caps using the nuts supplied, or using nuts with toothed washers. The recommended torque is 25 Nm.

To correctly tighten the self-piercing nuts follow the sequence shown in figure 7, based on the type of busbar being installed (single with 1, 2, or 3 nuts, double with 2, 4, or 6 nuts).

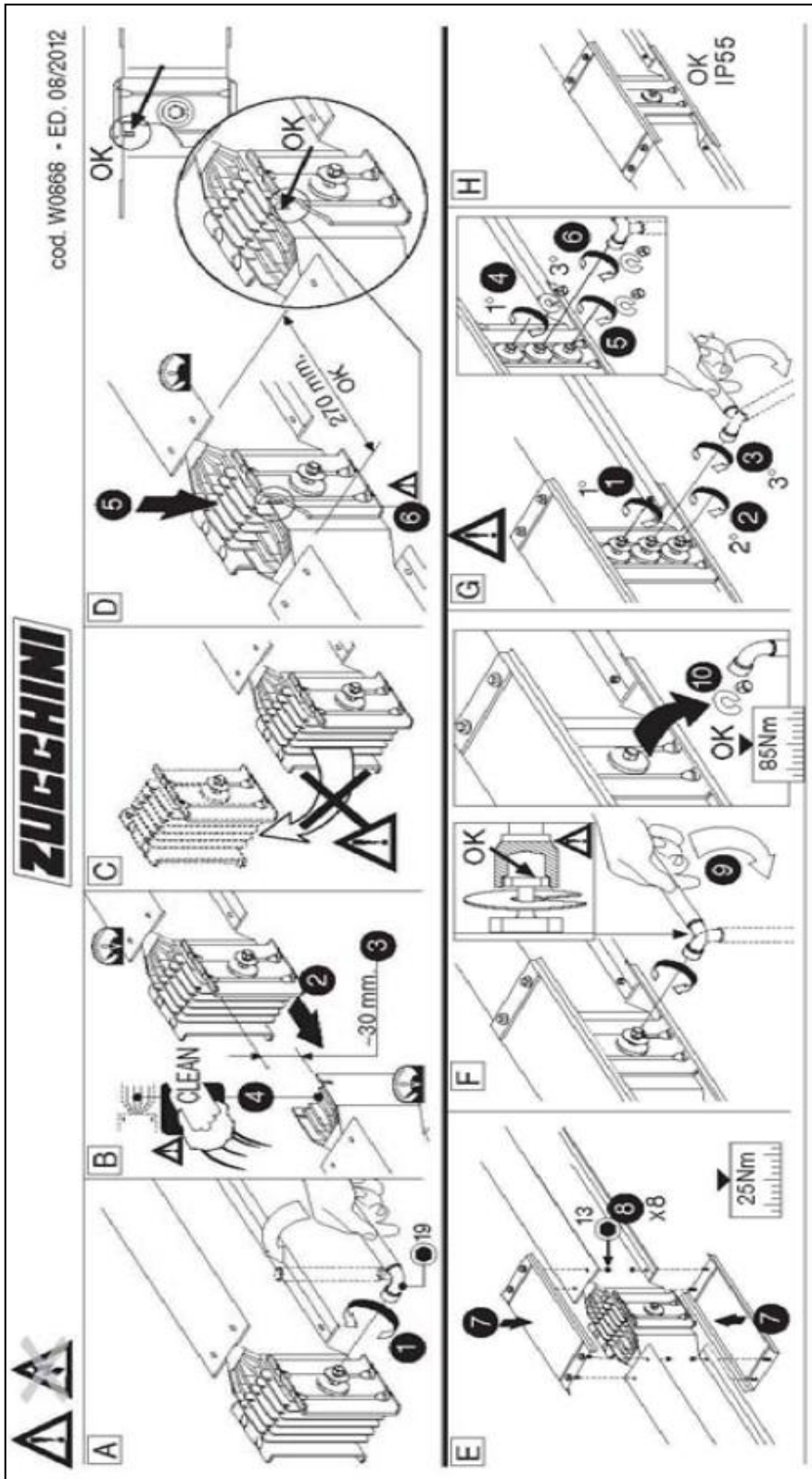

Fig. 6

Diagram for the connection of the elements of the busbar

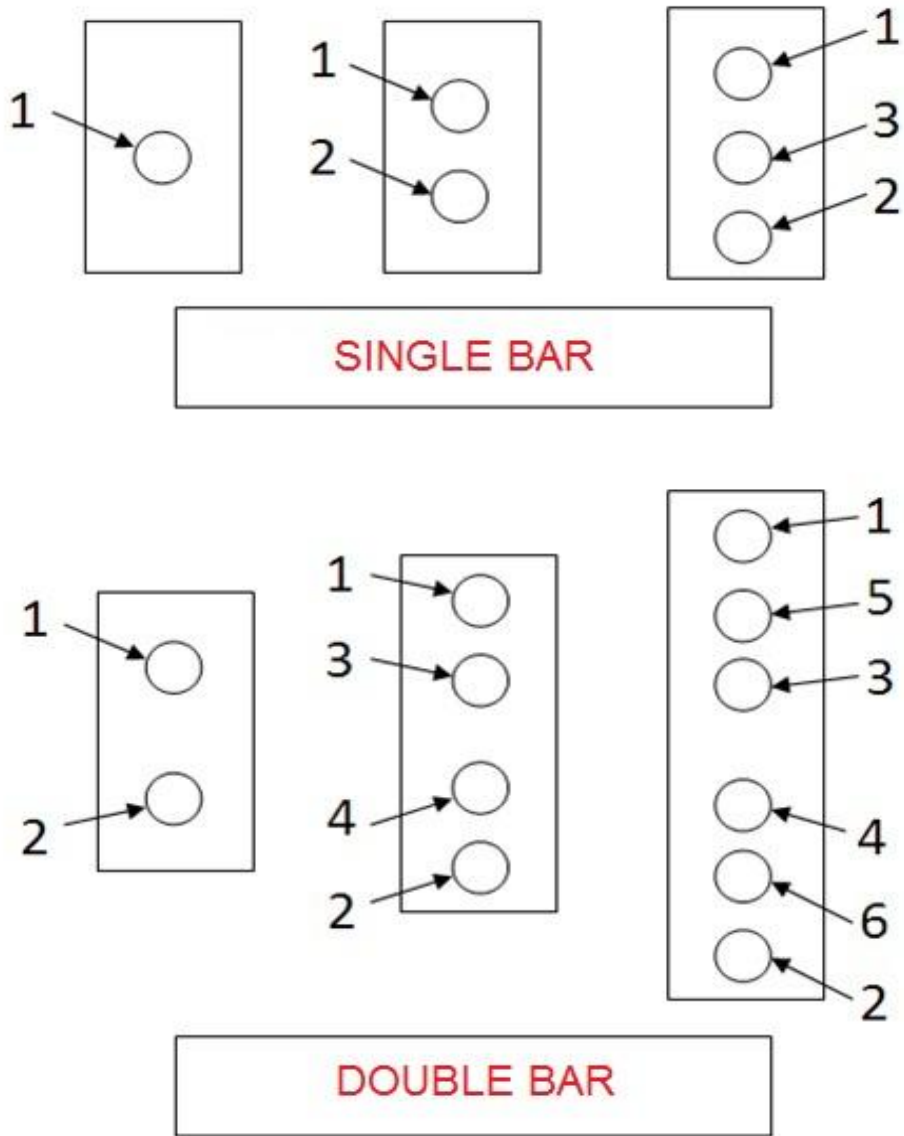

Fig. 7

Sequence for correct tightening of self-piercing nuts

To ensure correct installation of the busbar, during assembly complete the following checks:

- 1** check the alignment of the line along the three main directions
- 2** check the 270 mm distance between the two elements, see figure 8. This check can be completed using the joint cap.
- 3** check that the mechanical agreement of the monoblocs with the spaces of the elements is correct, see figure 9 and 10.
- 4** complete visual inspections to ascertain the status of the plastics (no broken or damaged plastics, and no foreign material), and the busbars
- 5** if opening the monobloc after assembly, new self piercing nuts when reassembling it are preferable. If refitting the existing ones, use a calibrated torque wrench. The torque must be 85 Nm, see figure 11.

NOTE: Do not open the monobloc: its individual parts cannot be bought as spare parts. If necessary, replace the whole monobloc. During assembly, do not use foreign materials (such as paints, silicon, or vaseline), both for the monobloc and the busbars.

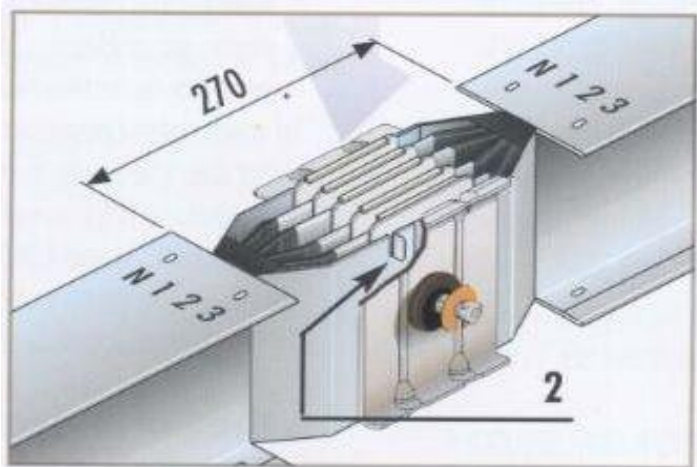

Fig. 8

Check that the distance between the two elements is 270 mm.

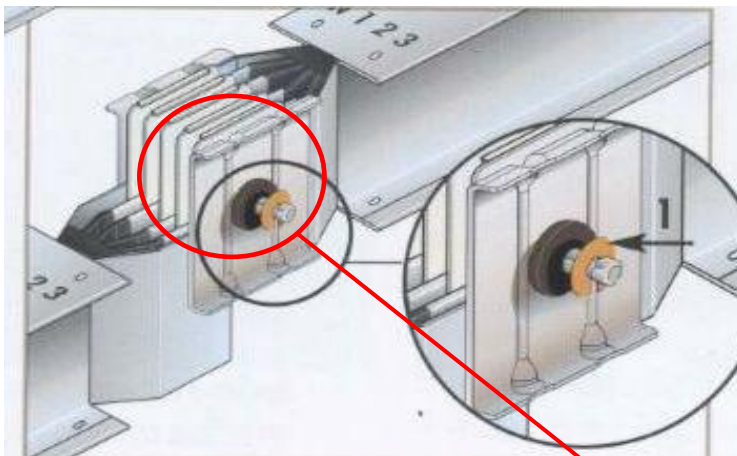
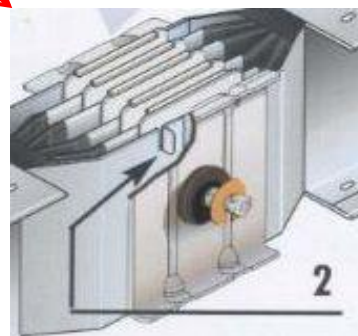

Fig. 9

check that mechanical agreement of the monoblocs with the spaces of the elements is correct.

Fig. 10



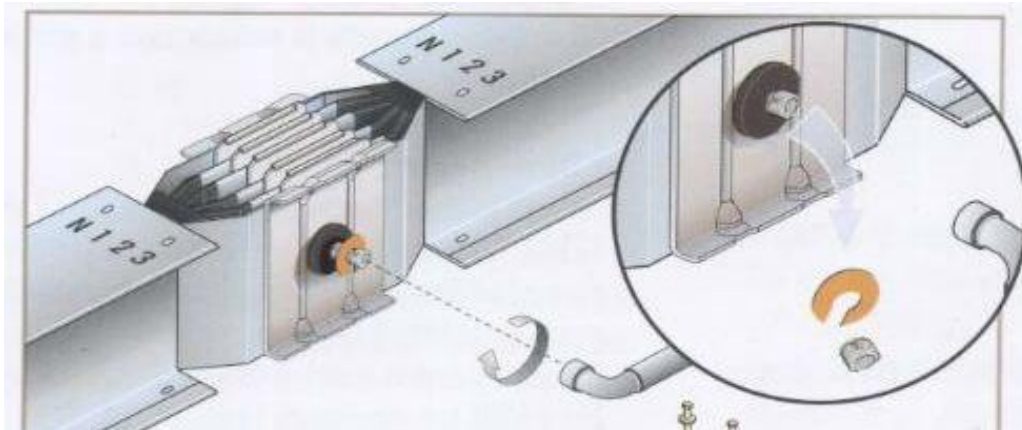

Fig. 11

Self-piercing nuts with rated torque 85 Nm.

After completing the installation as indicated in the previous paragraphs, at least the following checks must also be completed, to ensure that the busbar is ready for operation:

- 1** check the alignment of the line along the three main directions
- 2** check that all the self-piercing nuts have broken
- 3** check that all the joint caps have been fitted correctly
- 4** Complete the 1000 Vdc isolation test. An isolation resistance higher than 500 M Ω must be obtained
- 5** Measure the earth resistance of the system
- 6** The above tests are not a replacement, but rather an integration, of those required by the specific installation standards in the individual countries, or for specific

It is reminded that a busbar electric system must be regularly checked following the requirements of the applicable regulations, like Leg. Decree no. 81 dated 09/04/2008 (Consolidated act on health and safety in the workplace).

The checks to be completed are indicated in the check, control, and maintenance Instructions of SCP busbar systems.

**For further information, or for clarifications, contact the
Zucchini product support service**

T: +44 (0) 845 600 6266
F: +44 (0) 845 600 6760
E: powersales.uk@legrand.co.uk