

WORKSHOP SPECIFICATIONS

DMX³ and DMX³-I

AIR CIRCUIT BREAKERS
AND TRIP-FREE SWITCHES



A key component of the main distribution board, DMX³ air circuit breakers, available from 630 to 6300 A, provide protection and control at the supply end of low voltage installations.

Their efficiency not only ensures the safety of people and property, as well as continuity of service, it also promotes energy management through their advanced protection units.

These devices offer numerous accessory options, protection units, high performance levels and a rugged construction, all of which make them ideally suited to meet the needs of safety and energy management in installations.

LEGAL INFORMATION

Presentation pictures do not always include Personal Protective Equipment (PPE), but this is a legal and regulatory obligation that must be scrupulously respected.

In accordance with its continuous improvement policy, Legrand reserves the right to change the specifications and illustrations without notice. All illustrations, descriptions and technical information included in this document are provided as indications and cannot be held against Legrand.

CONTENTS

Safety instructions	2
The DMX ³ range	4
DMX ³ air circuit breakers	4
DMX ³ -I trip-free switches	5
Electrical accessories	6
Mechanical accessories	8
Connection accessories	10
Protection units	12
Logiciel PCS	14
Electrical accessories	20
Mechanical accessories	34
Connection accessories	40
DMX ³ installation in enclosures	44
Supply inverters	48
Ordering and delivery status of the DMX ³	52
Commissioning	56
Maintenance	58
Spare parts	62

SAFETY

INSTRUCTIONS

General information

- Use only the products and accessories recommended by the Legrand Group in the catalogue, instructions, technical data sheets and all other documents provided by Legrand (hereinafter referred to as «the Documentation») in compliance with the installation rules.
- Improper installation and/or use may result in the risk of arcing in the enclosure, overheating or fire. The enclosures must be used under normal conditions, they must not be subjected to Voltage / Current / Temperature values other than those specified in the Documentation.
- Legrand declines all responsibility for any modification or repair of the equipment making up the enclosure that is not authorized by the Legrand Group, as well as any failure to comply with the rules and recommendations specified by Legrand in the Documentation. In addition, in the cases mentioned above, the warranty granted by Legrand will not be applicable.
- It is necessary to check that the characteristics of the products are appropriate for their environment and use during maintenance operations, and to refer to the Documentation. If you have any questions or require clarification, please contact Legrand Group.
- The installation, use and maintenance of the enclosures and their components must be carried out by qualified, trained and authorized personnel, in accordance with the regulations in force in each country.



RISK OF ELECTRIC SHOCK, BURNS AND EXPLOSION.

- People working on the installation must have the appropriate electrical authorizations for the work to be carried out.
- Wear the PPE (Personal Protective Equipment) necessary to work on live products.
- Respect the safety rules related to electrical work.
- Improper electrical and mechanical use of equipment can be dangerous and may result in personal injury or damage to property.
- Depending on the maintenance operations to be carried out, partial or total power cuts of the enclosure concerned should be planned before any work.
- When performing operations that involve access to the inside of the enclosure, be aware of the risk of burns before touching any products or metal parts.
- Before turning the power back on, make sure that there are no foreign bodies and that all physical protections have been put back in place (e.g.: screens, covers, shields).

Any failure to strictly apply the procedures and to respect these recommendations, could lead to serious risk of accident, endangering people and property (in particular, without limitation, risk of burns, electric shocks, etc.).



 The rules and recommendations in this document are based on our knowledge of the typical conditions of use of our products in the fields of application usually encountered. However, it is always the customer's responsibility to verify and validate that Legrand products are suitable for its installation and use.

The customer must ensure proper installation, maintenance and operation of the equipment to avoid any risk of injury to personnel or damage to property in the event of product failure, especially for applications that require a very high level of safety (e.g., those in which the failure of a component may endanger human life or health).

The rules for storage, handling, installation and maintenance and the appropriate precautions and warnings must be strictly observed and applied.

THE DMX³ RANGE

Presentation
of the offer

DMX³ air circuit breakers

DMX³ air circuit breakers are available in 3 breaking capacities from 630 to 6300 A in just three sizes, in fixed and draw-out versions.



DMX³ 4-pole
Size 4000
Fixed version



DMX³ 3-pole
Size 2500
Draw-out version



DMX³ 4-pole
Size 6300
Fixed version

CHOICE OF AIR CIRCUIT BREAKERS

Icu [415 V~]		50 kA				65 kA				100 kA			
		FIXED		DRAW-OUT		FIXED		DRAW-OUT		FIXED		DRAW-OUT	
In (A)		3P	4P	3P	4P	3P	4P	3P	4P	3P	4P	3P	4P
DMX ³ 2500	630	0 286 20	0 286 30	0 287 20	0 287 30	0 286 40	0 286 50	0 287 40	0 287 50	0 286 60	0 286 70	0 287 60	0 287 70
	800	0 286 21	0 286 31	0 287 21	0 287 31	0 286 41	0 286 51	0 287 41	0 287 51	0 286 61	0 286 71	0 287 61	0 287 71
	1000	0 286 22	0 286 32	0 287 22	0 287 32	0 286 42	0 286 52	0 287 42	0 287 52	0 286 62	0 286 72	0 287 62	0 287 72
	1250	0 286 23	0 286 33	0 287 23	0 287 33	0 286 43	0 286 53	0 287 43	0 287 53	0 286 63	0 286 73	0 287 63	0 287 73
	1600	0 286 24	0 286 34	0 287 24	0 287 34	0 286 44	0 286 54	0 287 44	0 287 54	0 286 64	0 286 74	0 287 64	0 287 74
	2000	0 286 25	0 286 35	0 287 25	0 287 35	0 286 45	0 286 55	0 287 45	0 287 55	0 286 65	0 286 75	0 287 65	0 287 75
DMX ³ 4000	2500	0 286 26	0 286 36	0 287 26	0 287 36	0 286 46	0 286 56	0 287 46	0 287 56	0 286 66	0 286 76	0 287 66	0 287 76
	3200	0 286 27	0 286 37	0 287 27	0 287 37	0 286 47	0 286 57	0 287 47	0 287 57	0 286 67	0 286 77	0 287 67	0 287 77
	4000	0 286 28	0 286 38	0 287 28	0 287 38	0 286 48	0 286 58	0 287 48	0 287 58	0 286 68	0 286 78	0 287 68	0 287 78
DMX ³ 6300	5000									0 289 50	0 289 60	0 289 52	0 289 62
	6300									0 289 51	0 289 61	0 289 53	0 289 63

Units:

Size 2500

Size 4000

Size 6300

DMX³-I trip-free switches

DMX³-I trip-free switches are available in fixed and draw-out versions from 1250 to 6300 A.

Unlike DMX³ circuit breakers, where the spring charging handle is black, DMX³-I switches have a grey handle.



DMX³-I 3-pole
Size 2500
Fixed version

CHOICE OF TRIP-FREE SWITCHES

	In (A)	FIXED		DRAW-OUT		UNIT
		3P	4P	3P	4P	
DMX ³ -I 2500	1250	0 286 83	0 286 93	0 287 83	0 287 93	Size 2500
	1600	0 286 84	0 286 94	0 287 84	0 287 94	
	2000	0 286 85	0 286 95	0 287 85	0 287 95	
	2500	0 286 86	0 286 96	0 287 86	0 287 96	
DMX ³ -I 4000	3200	0 286 87	0 286 97	0 287 87	0 287 97	Size 4000
	4000	0 286 88	0 286 98	0 287 88	0 287 98	
DMX ³ -I 6300	6300	0 289 70	0 289 71	0 289 77	0 289 97	Size 6300

COLOUR CODE ON THE FRONT PANEL OF THE UNITS

DMX³ 2500
0 286 26
In=2500A

Icu(1s)=50kA
Ics=100% Icu
Uimp=12kV
Ui=1kV
IEC/EN 60947-2 Cat.B

legrand

DMX³ 6300
0 289 50
In=6000A

Icu(1s)=100kA
Ics=100% Icu
Uimp=12kV
Ui=1kV
IEC/EN 60947-2 Cat.B

legrand

- DMX³ 50 kA
- DMX³ 65 kA
- DMX³ 100 kA
- DMX³-I

DMX³ 4000
0 287 57
In=3200A

Icu(1s)=65kA
Ics=100% Icu
Uimp=12kV
Ui=1kV
IEC/EN 60947-2 Cat.B

legrand

DMX³-I 2500
0 287 94
Ie=1600A

Icu(1s)=65kA
Icm(415V)=143kA
Uimp=12kV
Ui=1kV
IEC/EN 60947-3 Cat.ACP3A

legrand

Electrical accessories and auxiliaries

Electrical accessories allow devices to be controlled and monitored remotely. These accessories are accessible from the front panel of the product and can be installed quickly and easily without the need for any special tools. All electrical accessories are common to the entire DMX³ range. To avoid any errors, each accessory has a dedicated slot.

INTERNAL AUXILIARIES AND ACCESSORIES

Undervoltage release or 2nd shunt trip

Shunt trip

Signalling contact for auxiliaries

Closing coil

Auxiliary contacts

Signalling contact for draw-out version (plugged in/test/drawn out)

"Ready to close" and "spring charged" contacts

Motor operator

EXTERNAL AUXILIARIES AND ACCESSORIES



External neutral



Programmable output module



Delay module for undervoltage release



External power supply

CHOICE OF ELECTRICAL ACCESSORIES AND AUXILIARIES

	24 Vac/dc	48 Vac/dc	110-130 Vac/dc	220-250 Vac/dc	415-480 Vac
Current shunt trip ▶ p. 15	0 288 48	0 288 49	0 288 50	0 288 51	0 288 52
Closing coil ▶ p. 14	0 288 41	0 288 42	0 288 43	0 288 44	0 288 45
Undervoltage release ▶ p. 16	0 288 55	0 288 56	0 288 57	0 288 58	0 288 59
Motor operator ▶ p. 17	0 288 34	0 288 35	0 288 36	0 288 37	0 288 38
Delay module ▶ p. 23	-	-	0 288 62	0 288 63	-
Auxiliary signalling contact ▶ p. 18				0 288 16	
Auxiliary contact ▶ p. 19				0 288 15	
Ready to close contact and spring charged contact ▶ p. 22				0 288 14	
Plugged in/test/drawn out position contact ▶ p. 21				0 288 13	
External power supply ▶ p. 24				0 288 06	
Programmable output module ▶ p. 26				0 288 12	
External neutral ▶ p. 27	Size 2500 and 4000: 0 288 11 - Size 6300: 0 288 10				

Mechanical accessories

Mechanical accessories help provide safety functions. A large majority of mechanical accessories are common to the entire DMX³ range.



Locking in open position



Padlocking in open position



Interlocking mechanism

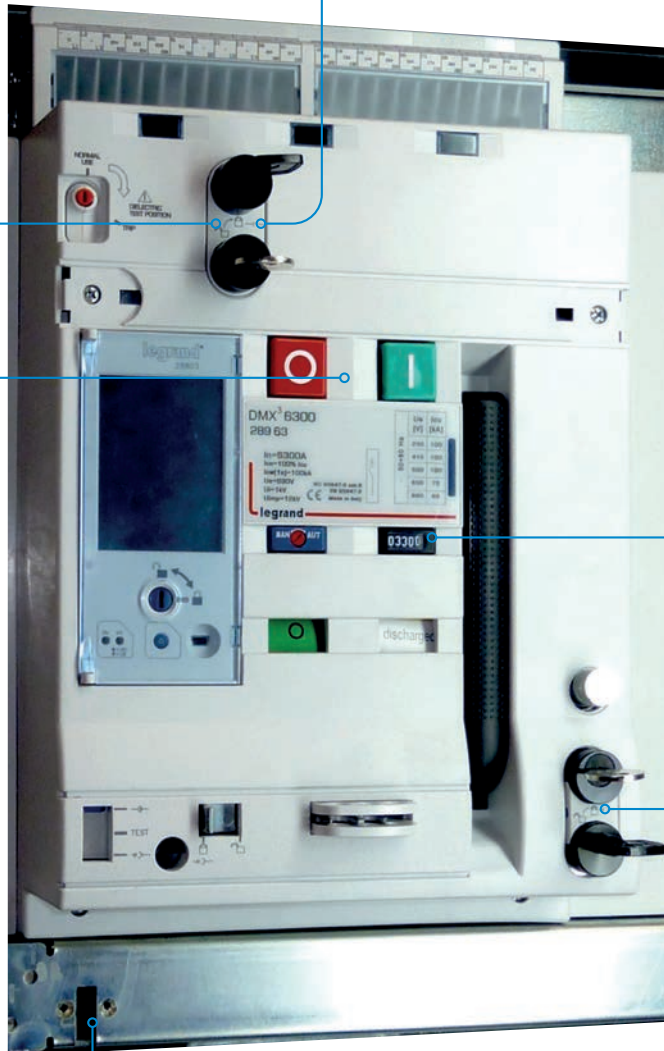

Padlocking for buttons



Operation counter



Door or faceplate lock



Locking in plugged in/
test/drawn out position



Lifting handles

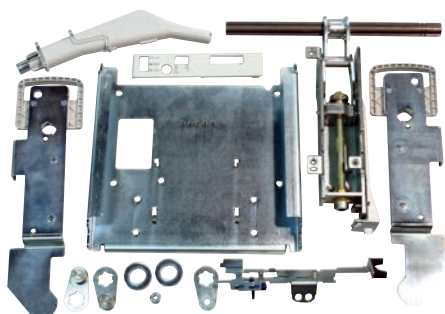

Fixed/draw-out conversion kit

Padlocking of safety shutters



Rating locating pin



BASE FOR DMX³ DRAW-OUT VERSION

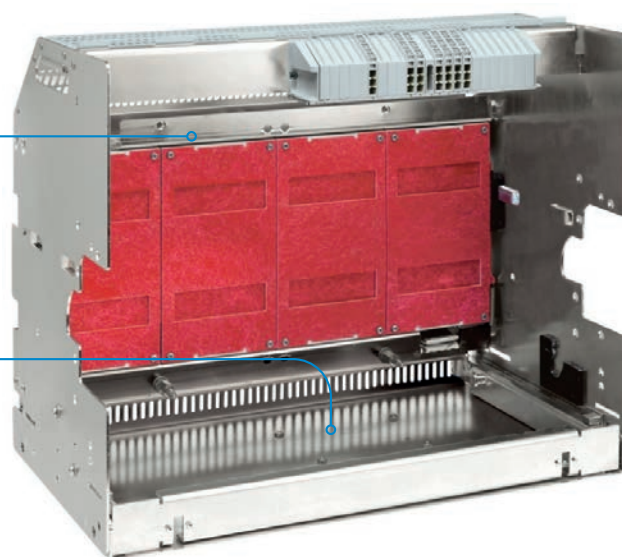

CHOICE OF MECHANICAL ACCESSORIES

		DESCRIPTION		SIZE 2500	SIZE 4000	SIZE 6300		
DRAW-OUT VERSION	Empty bases	▶ p. 33	3-pole	0 289 02	0 289 04	0 289 13		
			4-pole	0 289 03	0 289 05	0 289 14		
	Fixed/draw-out conversion kits	▶ p. 33	3-pole	0 289 09	0 289 11	0 289 15		
			4-pole	0 289 10	0 289 12	0 289 16		
SUPPLY INVERTERS	Interlocking mechanism	▶ p. 29		0 288 64	0 288 65	0 289 66		
			Interlocking cables	▶ p. 29	1 m		0 289 17	
					1.6 m		0 289 18	
					2.6 m		0 289 20	
					3 m		0 289 21	
					3.6 m		0 289 22	
					4 m		0 289 23	
					4.6 m		0 289 24	
					5.6 m		0 289 25	
LOCKING AND SECURITY	ALL VERSIONS	▶ p. 30	Locking in "Open" position (Lock + cylinder)		0 288 28 + 0 288 31			
			Set of 5 cylinders and keys for a combination of locking in "Open" position	▶ p. 30			0 288 27	
					Set of 5 cylinders and identical flat keys for locking in "Open" position	▶ p. 30		
			Padlocking in "Open" position	▶ p. 32			0 288 21	
			Door lock	▶ p. 31			0 288 20	
			Padlocking of O/I buttons	▶ p. 32			0 288 24	
	DRAW-OUT VERSION	▶ p. 30	Locking in plugged in/test/drawn out position	flat key		0 288 33		
				star key		0 288 32		
			Padlocking of safety shutters	▶ p. 31			0 288 26	
			Rating locating pin	▶ p. 31			0 288 25	
VARIOUS	▶ p. 28	Lifting handles			0 288 79			
		Operation counter	▶ p. 31			0 288 23		

Connection accessories

The different types of rear terminals can be mounted on the upstream and downstream DMX³ terminals allowing many connection configurations depending on the distribution system inside the enclosure (see page 36). The material used for the plates and fitting accessories, silver coated copper, enables connections in copper as well as aluminium.

DMX³ FIXED VERSION

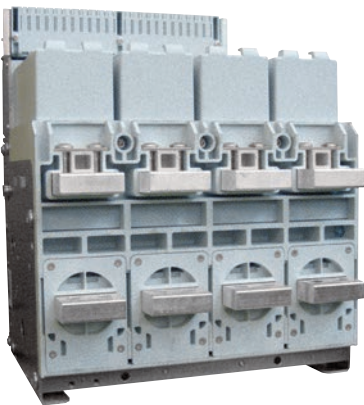

DMX³ fixed version:
horizontal connection plates







Insulated shields mounted
on the fixed DMX³ 3P

CONNECTION	ACCESSORIES	
Horizontal	-	
Flat	 Flat rear terminals	
Vertical	 Flat rear terminals + vertical rear terminals	
Flat	 Flat spreader	
Vertical	 Vertical spreader	
Horizontal	 Horizontal spreader	

DMX³ DRAW-OUT VERSION

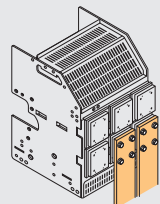

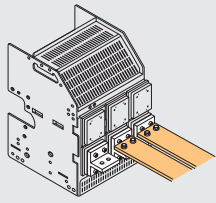
DMX³ draw-out version:
"flat" connection plates

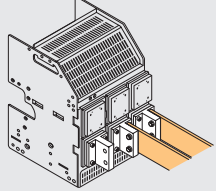
CONNECTION	ACCESSORIES	
Flat	-	
Horizontal	 Horizontal rear terminals	
Vertical	 Vertical rear terminals	

CHOICE OF CONNECTION ACCESSORIES





DESIGNATION		SIZE 2500	SIZE 4000	SIZE 6300	
FIXED VERSION	Flat rear terminals	3-pole	0 288 84	0 288 92	2 x 0 288 92
		4-pole	0 288 85	0 288 93	2 x 0 288 93
	Vertical rear terminals	3-pole	0 288 84 + 0 288 82	0 288 92 + 0 288 94	2 x 0 288 92 + 2 x 0 288 94
		4-pole	0 288 85 + 0 288 83	0 288 93 + 0 288 95	2 x 0 288 93 + 2 x 0 288 95
	Flat spreader	3-pole	0 288 86		
		4-pole	0 288 87		
	Vertical spreader	3-pole	0 288 88		
		4-pole	0 288 89		
	Horizontal spreader	3-pole	0 288 90		
		4-pole	0 288 91		
Insulated shields	3-pole		0 288 98		
	4-pole		0 288 99		
DRAW-OUT VERSION	Vertical rear terminals	3-pole	0 288 96	0 288 94	2 x 0 288 94
		4-pole	0 288 97	0 288 95	2 x 0 288 95
	Horizontal rear terminals	3-pole	0 288 96	0 288 94	2 x 0 288 94
		4-pole	0 288 97	0 288 95	2 x 0 288 95
	Insulated shields	3-pole		0 288 18	
		4-pole		0 288 19	

i Catalogue numbers marked as "3-pole" are composed of 3 parts.
Catalogue numbers marked as "4-pole" are composed of 4 parts.
For Size 6300 devices, the quantities are doubled.

Protection units

Protection units cannot be removed from the circuit breakers. It is not possible to order a circuit breaker alone, without its protection unit, and vice versa. They are factory assembled according to the circuit breaker on which they are installed. It is therefore prohibited to substitute protection unit.

DMX³ circuit breakers have a programmable relay controlled by a protection unit (see page 27). It is therefore necessary to use an external power supply (Cat.No 0 288 06) for the protection unit.

Protection units	LI	LSI	LSIg
MP4 (LCD screen)	 Cat.No 0 288 00	 Cat.No 0 288 01	 Cat.No 0 288 02
MP6 (touch screen)		 Cat.No 0 288 03	 Cat.No 0 288 04
Protection	<ul style="list-style-type: none"> - Long delay: Ir/tr - Instantaneous: li - Neutral 	<ul style="list-style-type: none"> - Long delay: Ir/tr - Short delay: lsd/tsd - Instantaneous: li - Neutral 	<ul style="list-style-type: none"> - Long delay: Ir/tr - Short delay: lsd/tsd - Instantaneous: li - Earth fault: Ig/tg - Neutral

Protection units have their own batteries, enabling adjustment and consultation of the circuit breaker protection unit without a load or without an external power supply.



The battery compartment, located underneath the electronic protection unit, is accessible from the front panel

To maintain an adequate battery charge level, and to ensure optimal use of the MP4 protection unit, it is advisable to limit the number of tests with batteries only to 5. Otherwise use the external power supply Cat.No 0 288 06.



When the battery charge is insufficient, the protection unit will show a text message or an icon, indicating the need to replace the battery.

LED indicators

PROTECTION STATUS	STATUS OF THE ON LED	STATUS OF THE xIr LED
Inactive	LED off	LED off
Active if: $I_1 + I_2 + I_3 \geq 100 \text{ A}$ or if $I \geq 130 \text{ A}$ on a single phase or if using an external power supply Cat.No 0 288 06	Green LED continuously on	LED off
Active with overload pre-alarm ($I > 0.9 \times Ir$)	Green LED continuously on	Red LED continuously on
Active with overload alarm ($I > 1.05 \times Ir$)	Green LED continuously on	Red flashing LED on
Active with overheating alarm ($T > 75 \text{ °C}$)	Green flashing LED on	Red flashing LED on
Any other operation of these LEDs indicates a protection unit malfunction; in this case, please contact Legrand Customer Service		

 Above 95 °C, the protection unit trips (the temperature measured is that of the protection unit and not that of the power contacts).

ADJUSTMENT STEPS

VALUES	SETTINGS	INFORMATIONS
I_r	0.4 to $1 \times I_n$	→ in steps of $0.02 \times I_n$ for the MP4 → in steps of $0.01 \times I_n$ for the MP6
t_r	5-10-20-30 s	Mem = ON/OFF
I_{sd}	1.5-2-2.5-3-4-5-6-8-10 $\times I_r$	
t_{sd}	→ 0-0.1-0.2-0.5-1 s at constant t or $0.1-0.2-0.5-1$ s at I_{2t} constant t for the MP4 → 0 to 1 s at constant t or constant I_{2t} in steps of 0.1 for the MP6	
I_g	0.2-0.3-0.4-0.5-0.6-0.7-0.8-1 $\times I_n$ or OFF	
t_g	0.1-0.2-0.5-1 s at constant t or constant I_{2t}	
I_i	2-3-4-6-8-10-12-15 $\times I_n$ or OFF (I_{cw})	
Neutral	Off/50/100 % $\times I_r$ / I_{sd}/I_i	
I_f	fixed (non-adjustable) = I_{cw}	

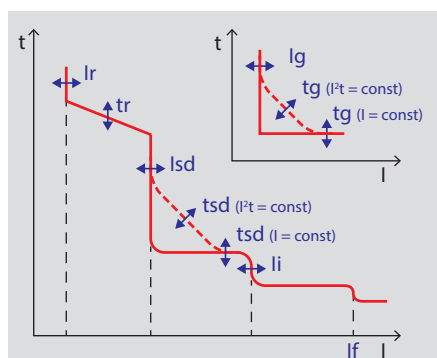

MP4 PROTECTION UNIT WITH LCD SCREEN

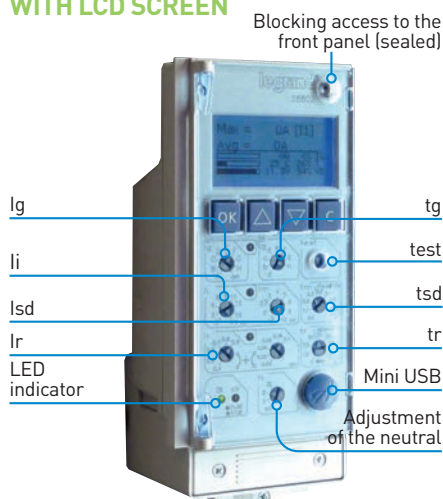

The number of adjustment buttons varies depending on the protection unit, but their location on the front panel remains unchanged.

If the unit is powered by an external power supply, the LEDs located near the I_g , I_{sd} and I_r adjustment buttons indicate the origin of the trip caused by the protection unit (earth fault, short circuit or overload/overheating respectively).

Each MP4 protection unit with LCD screen has 2 display languages. English is default language and the second language can be selected from the following list: French, Italian, Turkish, Spanish, Portuguese, Russian, and Chinese.



For more information, refer to the Y2687 guide available in the E-catalogue at www.export.legrand.com.

MP6 ADVANCED PROTECTION UNIT WITH TOUCH SCREEN

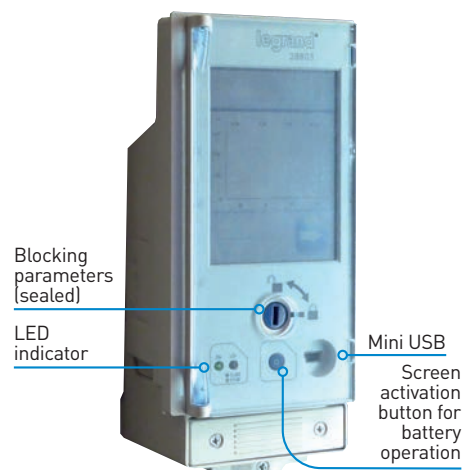

The front panel of the advanced protection unit is identical for both catalogue numbers.

With only battery power, after pressing the activation button on the MP6 protection unit, the default page appears after about 1 minute.

The test function is not available when power is supplied by batteries only. It is necessary to use the external power supply Cat.No 0 288 06.

When the circuit breaker is operating, or with an external power supply (ON LED lit), screen activation is immediate after touching the touch screen.



For more information, refer to the Y3838 guide available in the E-catalogue at www.export.legrand.com.

PCS SOFTWARE

Legrand power control station is intuitive and easy to use. It is a tool for consulting and testing the proper functioning of the electronic card that equips our electronic devices of the DMX³ range (except DMX³ 1600)-all electronic and thermal magnetic with integrated fault current protection DX³ add-on modules with integrated measurement-CX³ EMS. It is very useful for the maintenance service, to check the shape of the adjustment curve, to visualize the fault history and to check the different parameters directly on the device without touching the device. The software is available in 13 languages.

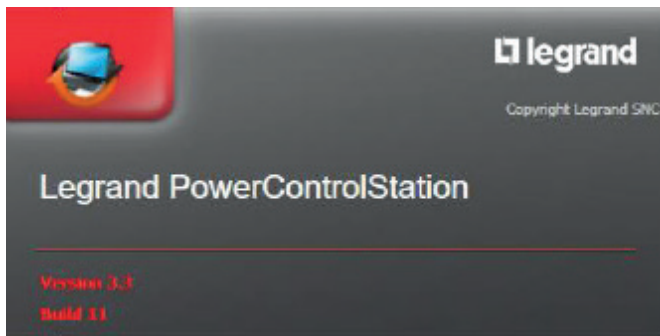

THE MINIMUM REQUIREMENTS OF THE COMPUTER TO RUN THE SOFTWARE :

- PC with Pentium III class processor
- Minimum RAM memory required 1GB, recommended 2GB
- Resolution 1024 x 768
- Colors 32 bit
- Pre-requisite mouse software
- Windows 7 or higher
- Microsoft.NET 4.0 or upgrade

■ Mini USB cable type B



The different access levels are available for each user category:

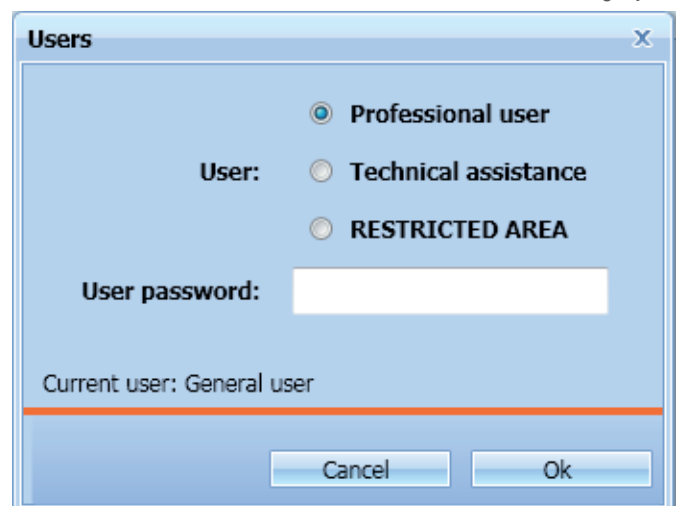

- Standard user → no password
- Business user → password 0000
- Legrand technical support → confidential
- Reserved area → confidential

COMPATIBILITY TABLE WITH VERSION 3.3 PCS :

Product	Version	Range	Minimum compatible version
DMX ³	MP4	2500-4000-6300	Screen software 2.5.5.X
	MP6	2500-4000-6300	Screen software 3.2.X

Product	Version	Range	Minimum compatible version
DPX ³	160	Thermal magnetic with earth fault protection	rev. 5 (*half 2016)
		Only earth fault protection	rev. 5 (*half 2016)
	250	Thermal magnetic with earth fault protection	rev. 5 (*half 2016)
		Only earth fault protection	rev. 5 (*half 2016)
		Electronic	rev. 4
		Electronic with earth fault protection	rev. 4
	630	Electronic	rev. 4
	1600	Electronic	rev. 2

The installation procedure and connection to the software, please refer to the instructions LE08865AB.

The different functions of the software :

- Firmware update: run the device firmware update feature. This operation is reserved exclusively for Legrand qualified personnel.

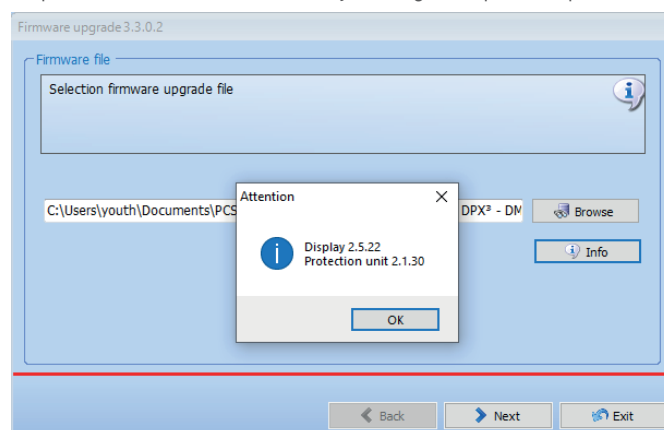

- Print on the file: create a complete file containing all the data read by the software and present on the device. ("...\Documents\legrand\legrand_powercontrolstation_03xx \ log").

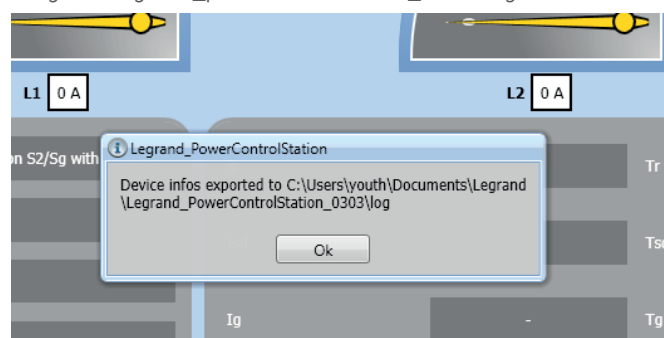

- Start monitoring: read the device information (versions – parameters – fault histories, etc.). The different pages of readings :

The yellow/white bar at the bottom of the page on the right is activated.

■ Home page



■ General list

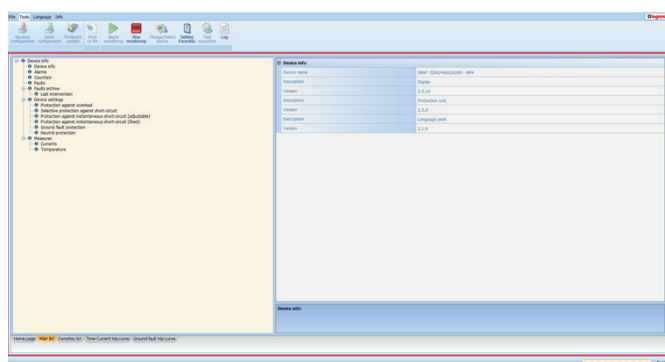

■ Favorites list

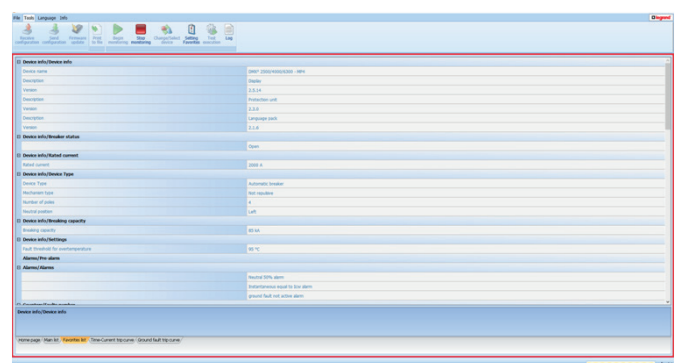

■ Tripping curves

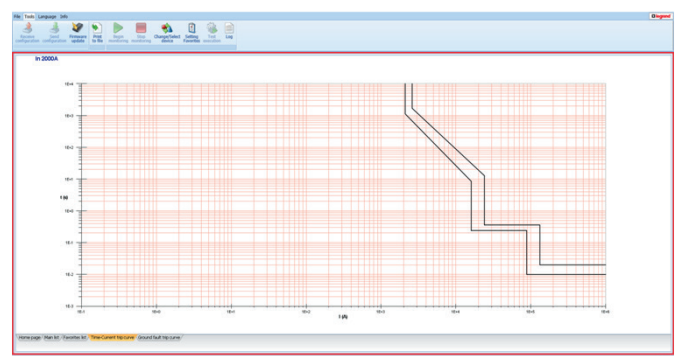

- Stop monitoring: stop playback of the device (the yellow/white bar at the bottom of the page on the right is no longer active).



- Change/select device: in case of a prolonged shutdown, click on this tab to refresh the connection with the connected device.
- Favorite setting: in this tab, you can find all the information gathered on a single tab, version of the device, its settings, defect histories, etc...
- Test run: allow the device to be checked for proper operation. Attention, to ensure proper operation of this test, it is imperative to check that the device is properly powered (external power supply for electronic circuit breaker and mains supply for differential circuit breaker).

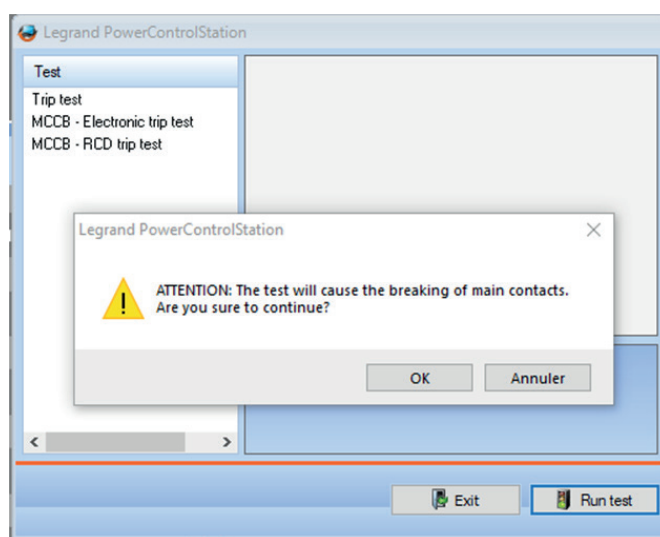

- Log: create and save the different steps of communication with the device (for all operations of the firmware update, think about clicking "Log").

Front panel of the DMX³

To remove the front panel of the DMX³, remove both positive screws behind the front panel covers, as well as both screws at the bottom, recessed from the front panel.

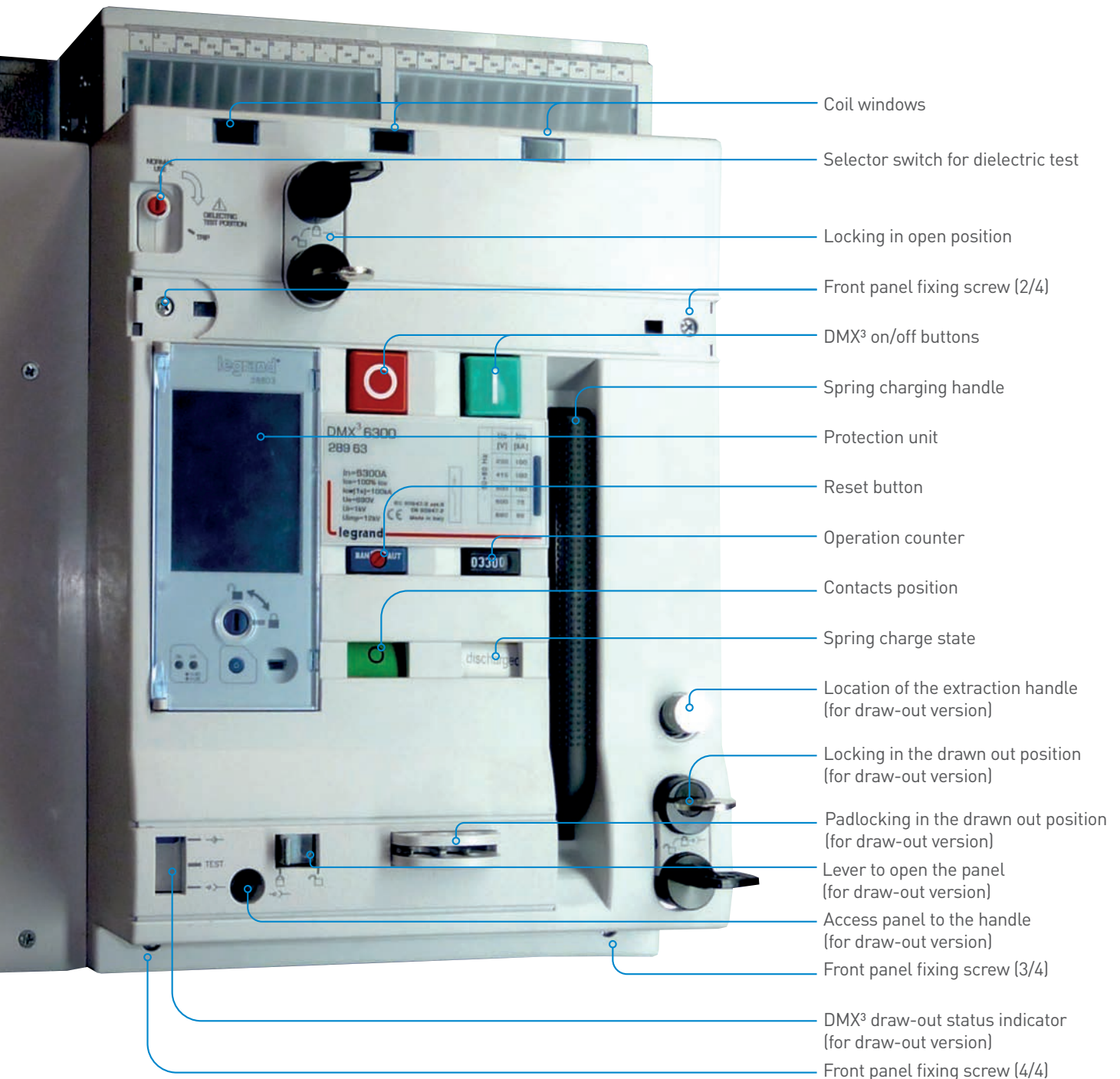

- Coil windows
- Selector switch for dielectric test
- Locking in open position
- Front panel fixing screw (2/4)
- DMX³ on/off buttons
- Spring charging handle
- Protection unit
- Reset button
- Operation counter
- Contacts position
- Spring charge state
- Location of the extraction handle (for draw-out version)
- Locking in the drawn out position (for draw-out version)
- Padlocking in the drawn out position (for draw-out version)
- Lever to open the panel (for draw-out version)
- Access panel to the handle (for draw-out version)
- Front panel fixing screw (3/4)
- DMX³ draw-out status indicator (for draw-out version)
- Front panel fixing screw (4/4)

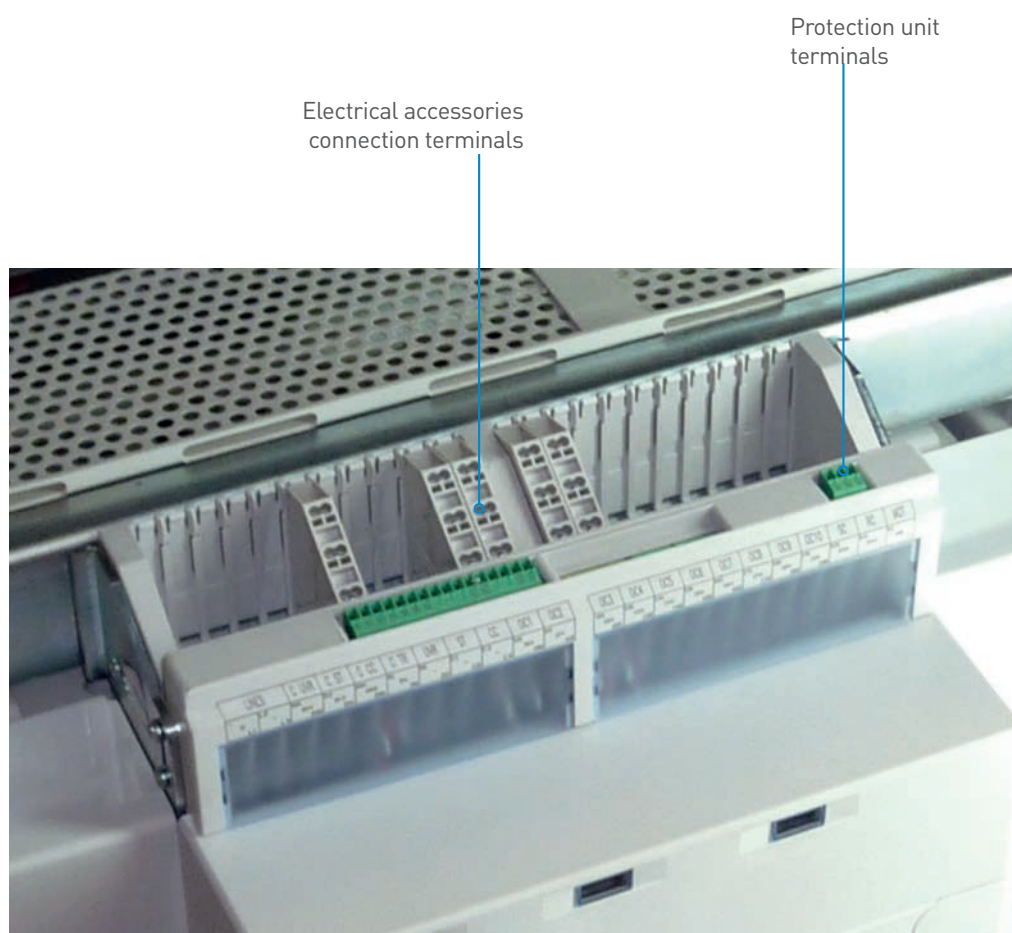

i On DMX³ draw-out air circuit breakers, the protection unit terminals must be connected so that you can draw out the DMX³ without applying mechanical stress on it. Leave enough cable to allow the draw out operation.

ELECTRICAL ACCESSORIES

Characteristics

Closing coil

If the spring is charged and the protection unit is not indicating a fault, this accessory allows to close the contacts of the DMX³ by energising the coil.

The rising edge of this electrical command is given by a NO external contact (for example a PLC output) and not by the protection unit.

The closing coil comes with a connector (male + female) to be inserted into slots C3 and C4 on the DMX³ terminal block.

Only one closing coil can be installed per device. This is located in the 3rd slot marked "CC". It can be inserted by rotating it to the left and removed by rotating it to the right. The closing coil can support being energised permanently.

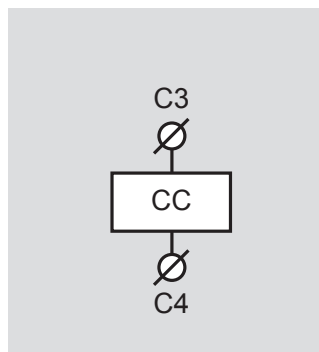

TECHNICAL CHARACTERISTICS

- Nominal voltage V_n:
 - 24/48/110-130/220-250/415-480 Vac
 - 24/48/110-130/220-250 Vdc
- Operating range: 85 to 110% V_n
- Inrush power: 500 W/VA
- Inrush duration: 180 ms
- Holding power: 5 W/VA
- Maximum closing time: 50 ms
- Insulation voltage: 2.5 kV



After an opening command, it is necessary to allow a period of 50 ms before issuing a closing command.

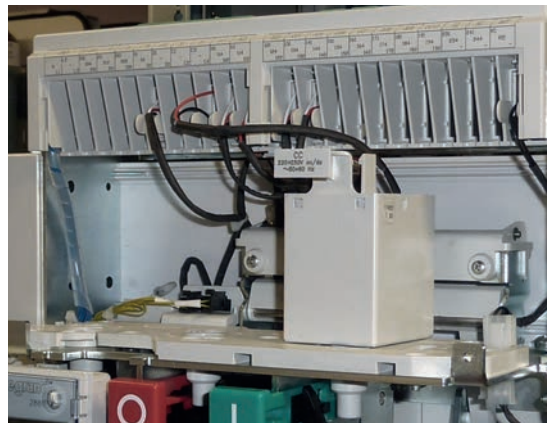

Current shunt trip

The current shunt trip allows instantaneous opening of the DMX³ by energising the coil (negative safety).

The rising edge of this electrical command is given by a NO external contact (for example an emergency stop) and not by the protection unit.

The current shunt trip comes with a connector (male + female) to be inserted into slots C1 and C2 on the DMX³ terminal block.

It is possible to equip the DMX³ with two shunt trips: the first is placed in the slot marked "ST" and the second is placed in the slot for the undervoltage release marked "UVR". In this case, the second shunt trip will be connected to terminals D1 and D2.

It can be inserted by rotating it to the left and removed by rotating it to the right.

The current shunt trip can support being energised permanently.



After a closing command, it is necessary to allow a period of 50 ms before issuing an opening command.

TECHNICAL CHARACTERISTICS

- Nominal voltage V_n:
 - 24/48/110-130/220-250/415 Vac
 - 24/48/110-130/220-250 Vdc
- Operating range: 70 to 110% V_n
- Inrush power: 500 W/VA
- Inrush duration: 180 ms
- Holding power: 5 W/VA
- Maximum closing time: 30 ms
- Insulation voltage: 2.5 kV

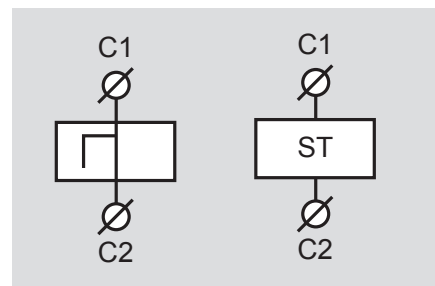

Two different symbols are used to illustrate shunt trips

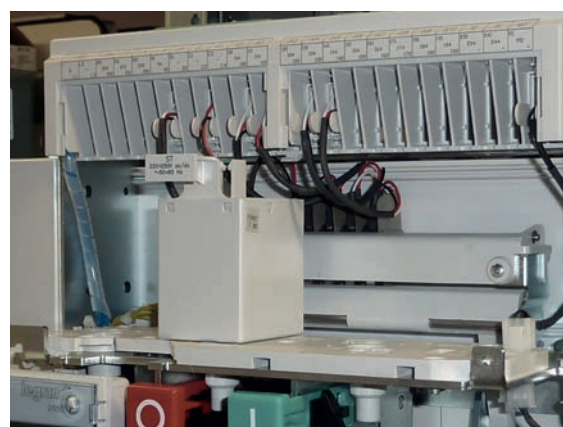

Undervoltage release

The undervoltage release allows instantaneous opening of the DMX³ by de-energising the coil (positive safety).

The descending edge of this electrical command is given by a NC external contact (for example an emergency stop) and not by the protection unit.

The undervoltage release comes with a connector (male + female) to be inserted into slots D1 and D2 on the DMX³ terminal block.

The DMX³ can only take one undervoltage release.

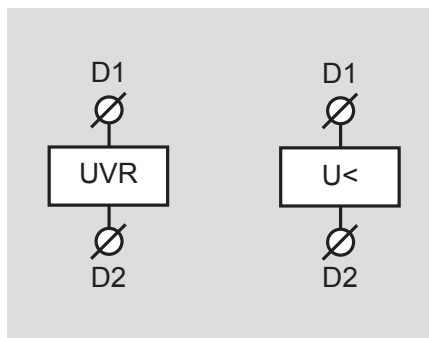

Two different symbols are used to illustrate undervoltage releases



TECHNICAL CHARACTERISTICS

- Nominal voltage Vn:
 - 24/48/110-130/220-250/415 Vac
 - 24/48/110-130/220-250 Vdc
- Operating range: 85 to 110% Vn
- Inrush power: 500 W/VA
- Inrush duration: 180 ms
- Holding power: 5 W/VA
- Maximum closing time: 60 ms
- Insulation voltage: 2.5 kV

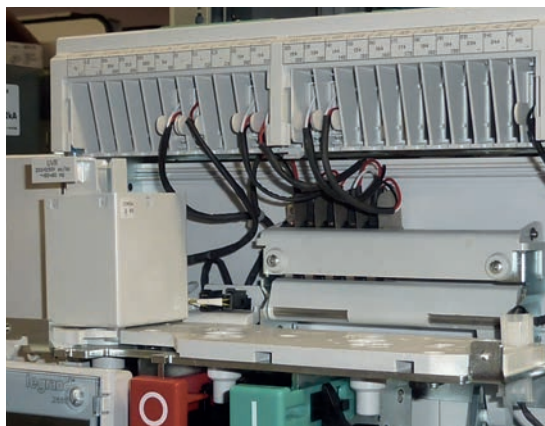

Motor operator

The motor operator is used to reset the closing spring automatically. Its starting and stopping are automatic if voltage is present at its terminals.

It is preferable to have a constant voltage at the terminals so that the DMX³ can operate quickly.

The motor operator is protected by a 5 x 20 - 250 Vac - 10 A internal time-delay fuse. For safety reasons, fuse replacements must be performed with the power off.

The motor operator comes with a connector (male + female) to be inserted into slots M1 and M2 slots on the DMX³ terminal block.

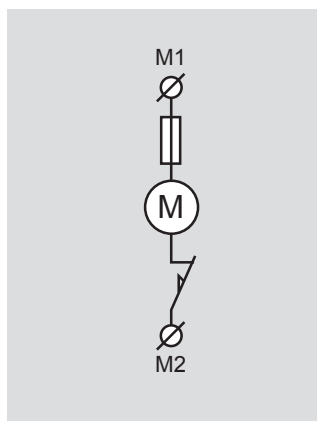

TECHNICAL CHARACTERISTICS

- Nominal voltage V_n:
 - 24/48/110-130/220-250/415 Vac
 - 24/48/110-130/220-250 Vdc
- Operating range: 85 to 110% V_n
- Maximum power consumption:
 - 180 W/VA (Size 2500) 240 W/VA (Size 4000 and 6300)
- Inrush current: 2 to 3 x I_n
- Charging time:
 - Size 2500: 5 s
 - Size 4000 and 6300: 7 s
- Maximum operation frequency:
 - Size 2500: 2/minute
 - Size 4000 and 6300: 1/minute

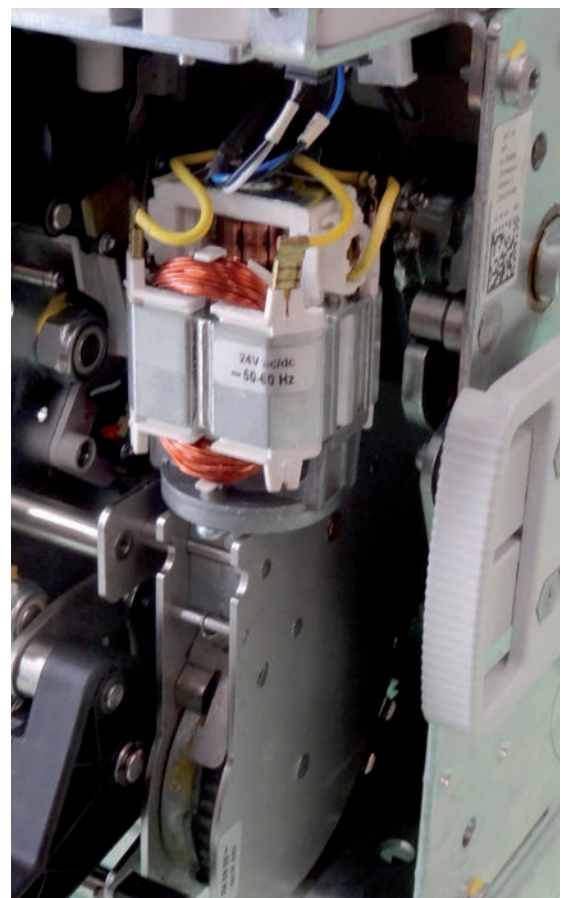

signalling contact

This contact is used to indicate the remote status of the various shunt trips, undervoltage releases and closing coils present in the DMX³.

This contact is a volt-free changeover (NO/NC) contact.

Only one contact can be installed per trip unit, release or coil.

This contact comes with a connector (male + female).

Slot for the connector on the DMX³ terminal block:

- C UVR: 201/202/204 for the undervoltage release.
- C ST: 211/212/214 for the current shunt trip.
- C CC: 221/222/224 for the closing coil.

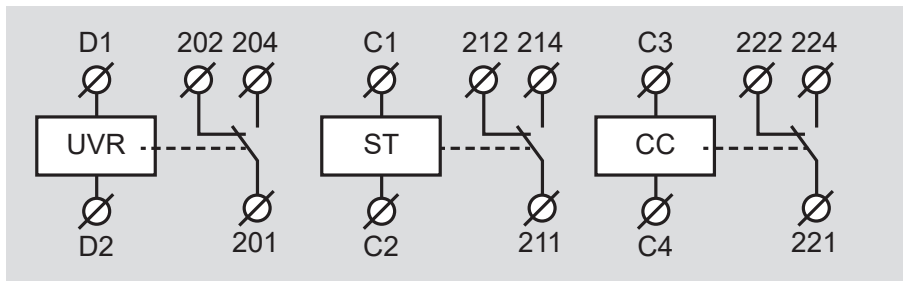

TECHNICAL CHARACTERISTICS

- Maximum voltage: 250 Vac/dc
- Nominal rating:
 - 16 A from 125 Vac to 250 Vac
 - 0.6 A at 125 Vdc
 - 0.3 A at 250 Vdc

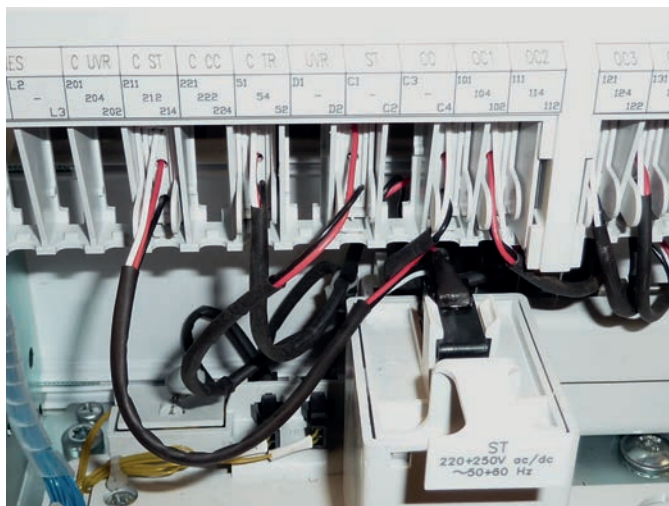

The signalling contact is mounted on top of the coil trip unit or releases.

Auxiliary contacts

Auxiliary contacts are used to indicate the position of the main contacts of the DMX³ remotely.

These contacts are volt-free changeover (NO/NC) contacts.

When the DMX³ poles are open, the contact is closed between terminals 1x1 and 1x2.

All DMX³ and DMX³-I come with four pre-installed auxiliary contacts. It is possible to add six optional contacts for a total of up to ten auxiliary contacts.

These contacts come with a connector (male + female) and a side shield for better insulation.

TECHNICAL CHARACTERISTICS

- Maximum voltage: 250 Vac/dc
- Nominal rating:
 - 16 A from 125 Vac to 250 Vac
 - 0.6 A at 125 Vdc
 - 0.3 A at 250 Vdc

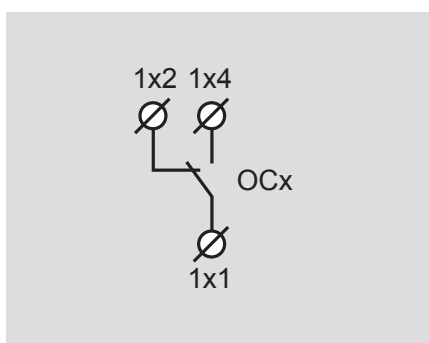

"OC" = "Open Close"

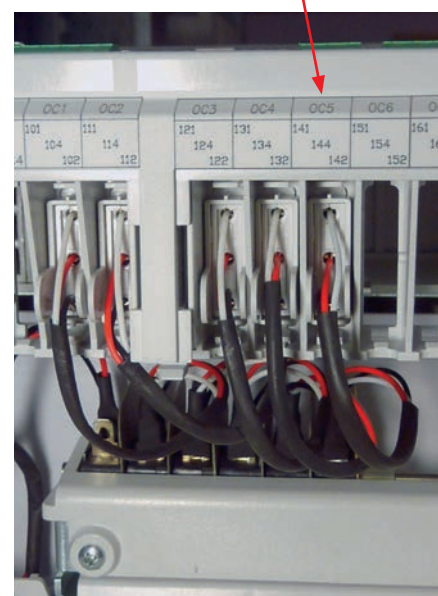
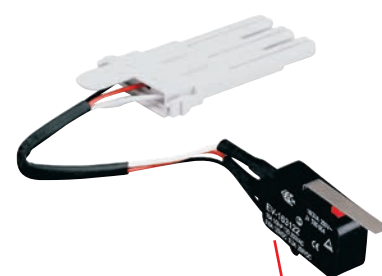

Four pre-installed auxiliary contacts and an optional auxiliary contact

	CONTACTS	SLOT ON THE DMX ³ TERMINAL BLOCK	TERMINALS
Pre-installed	1	OC1	101/102/104
	2	OC2	111/112/114
	3	OC3	121/122/124
	4	OC4	131/132/134
Optional	5	OC5	141/142/144
	6	OC6	151/152/154
	7	OC7	161/162/164
	8	OC8	171/172/174
	9	OC9	181/182/184
	10	OC10	191/192/194

Fault contact

The fault contact provides remote feedback on circuit breaker operation after a command issued by the protection unit (fault or test).

All DMX³ circuit breakers are equipped as standard with a fault contact. It is not physically accessible. On the terminal block, this contact is connected to the slot marked "C TR" at terminals 51/52/54.

There is only one fault contact per DMX³ circuit breaker.

The fault contact can be rendered non-maintained if the reset button is set to AUTO. If this is the case, the fault contact will switch for a period between 15 and 20 ms.

This contact is a volt-free changeover (NO/NC) contact.

In a normal state, not tripped, terminals 51 and 52 are closed.

TECHNICAL CHARACTERISTICS

- Maximum voltage: 250 Vac/dc
- Nominal rating:
 - 6 A from 125 Vac to 250 Vac
 - 0.6 A at 125 Vdc
 - 0.3 A at 250 Vdc

i DMX³-I trip-free switches cannot be equipped with a CTR fault contact.

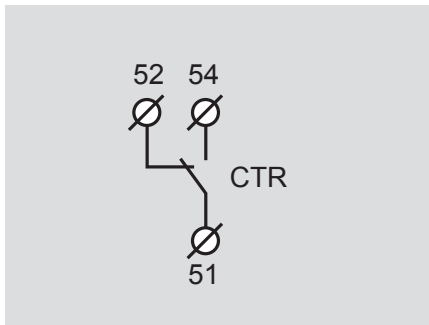

"CTR" = "Contact TRip"

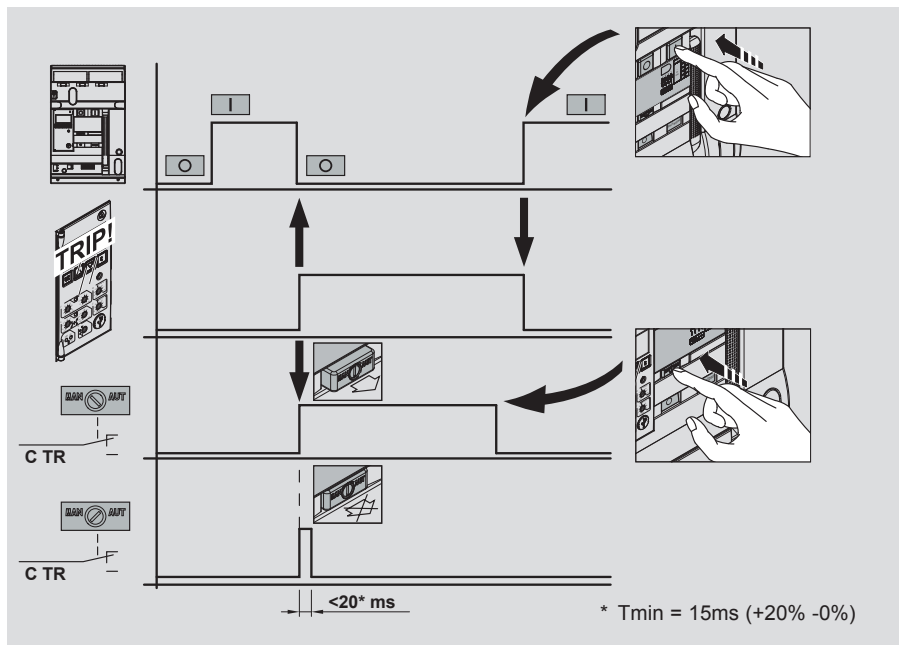
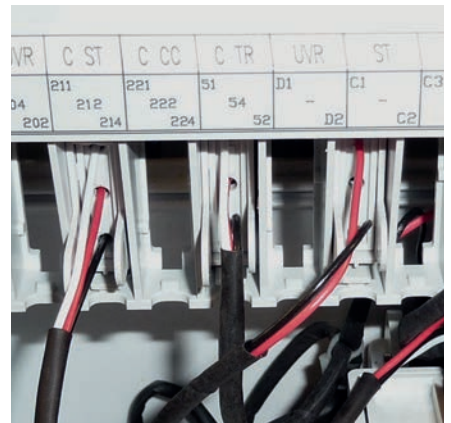

"Plugged IN/TEST/DRAWN OUT" Contact block

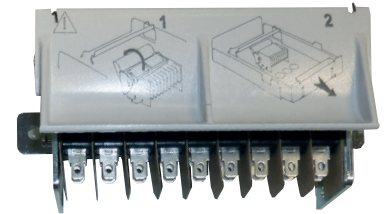

These contacts provide remote feedback regarding the position of a draw-out DMX³ in its base: "plugged in", "test" or "drawn out".

Each contact has a specific function that cannot be changed.

The block has nine contacts: three for the presence of the DMX³ in the base, three for the test position and three for the plugged-in position.

These contacts are volt-free changeover (NO/NC) contacts.

Only one contact block can be installed per draw-out DMX³.

The electrical connection is via isolated 6.3 mm Faston lugs (contact block comes with 27 insulated lugs).

TECHNICAL CHARACTERISTICS

- Maximum voltage: 250 Vac/dc
- Nominal rating:
 - 16 A from 125 Vac to 250 Vac
 - 0.6 A at 125 Vdc
 - 0.3 A at 250 Vdc

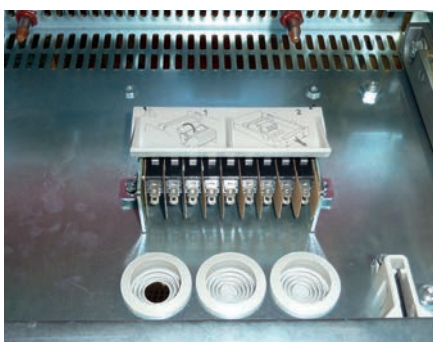
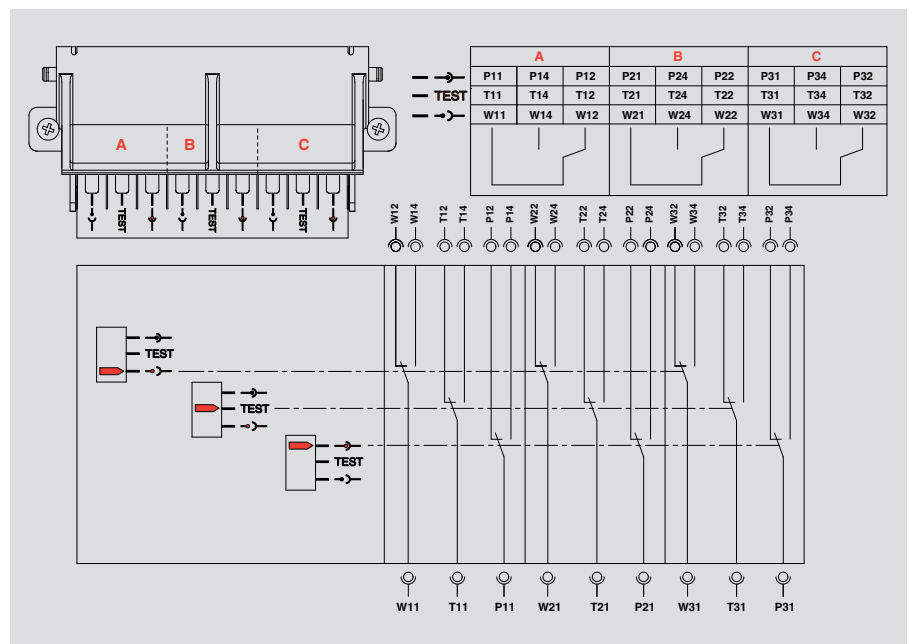

The contact block is mounted inside the base

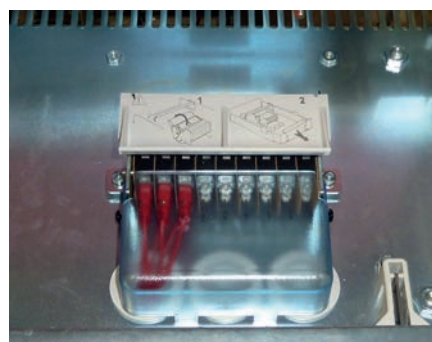

The insulating cover protects the terminals



The plate mounted under the DMX³ actuates the contacts during the plug-in and draw-out operations

i If handling the chassis unit without the DMX³, it is necessary to tilt the contact block cover before removing the empty chassis unit.

! When replacing a draw-out product, do not forget to retrieve the plastic plate beneath the DMX³.

"Ready to close" contact and "spring charged" contact

This contact block provides remote feedback of two distinct types of information:

- Device ready to close (RC): the contact is closed when the spring is charged, as long as there is no fault detected on the circuit breaker and all safety systems allowing closure are inactive.
- Spring charged: (SC): the contact is closed when the spring is fully charged (electrically or manually).

When installing this contact block, check properly that the two pins are in the right place.

These contacts are volt-free changeover (NO) contacts.

On the DMX³ terminal block, the "ready to close" contact connects to the "RC" slot at terminals 241/244 and the "spring charged" contact connects to the "SC" slot at terminals 231/234.

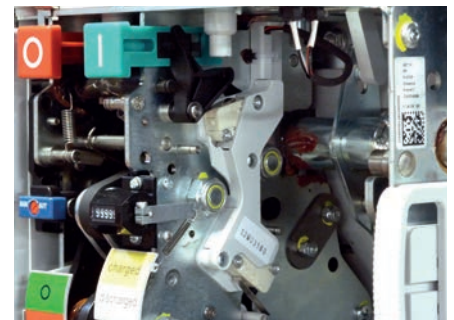
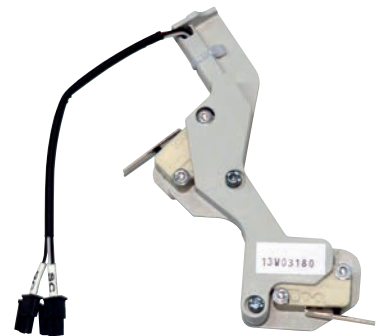
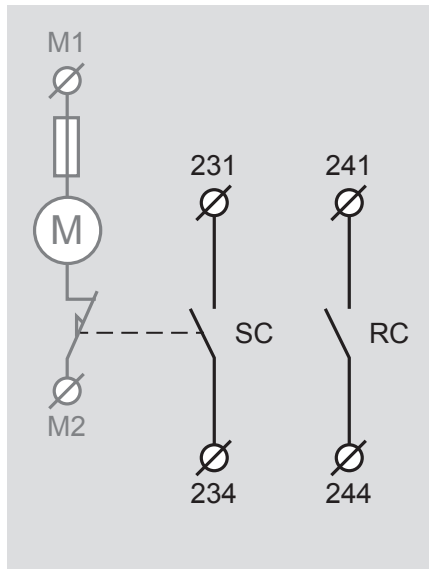

Contact block mounted inside the DMX³

TECHNICAL CHARACTERISTICS

- Maximum voltage: 250 Vac/dc
- Nominal rating:
 - 16 A from 125 Vac to 250 Vac
 - 0.6 A at 125 Vdc
 - 0.3 A at 250 Vdc

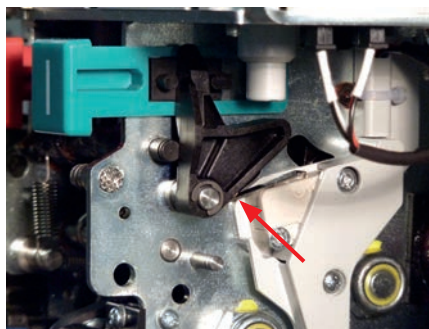

RC contact pin

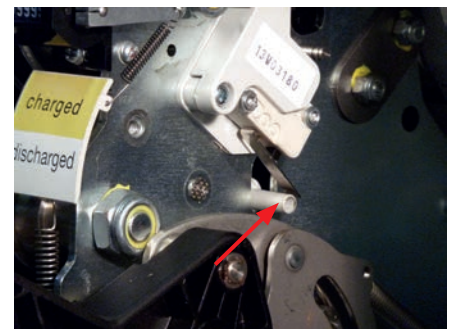

SC contact pin

Delay modules

These modules are used to delay the intervention of an undervoltage release installed in a DMX³ by up to three seconds during a micro-break.

These delay modules combine with standard undervoltage releases Cat.No 0 288 57 (110 V) and Cat.No 0 288 58 (230 V). A single module is used to obtain a delay of one second. Connecting three modules in series obtains a maximum delay of three seconds.

When using an emergency stop, it must be of type NC, and should be placed between the output of the last delay module and the undervoltage release.

Before turning on the delay module, you must ensure that the undervoltage release is connected. Power the module for at least one second to obtain its full operating capacity. Multiply this time by the number of modules installed. Before working on the wiring downstream of the delay module, wait a minute after switching off the power supply to avoid any electric shocks.

Protection for this delay module must be placed upstream of the DMX³ where the undervoltage release is to be installed.

TECHNICAL CHARACTERISTICS

- Input voltage:
 - Cat.No 0 288 62:
 - 110 Vdc ±10%
 - 110 Vac ±10% 50/60 Hz
 - Cat.No 0 288 63:
 - 230 Vdc ±10%
 - 230 Vac ±10% 50/60 Hz

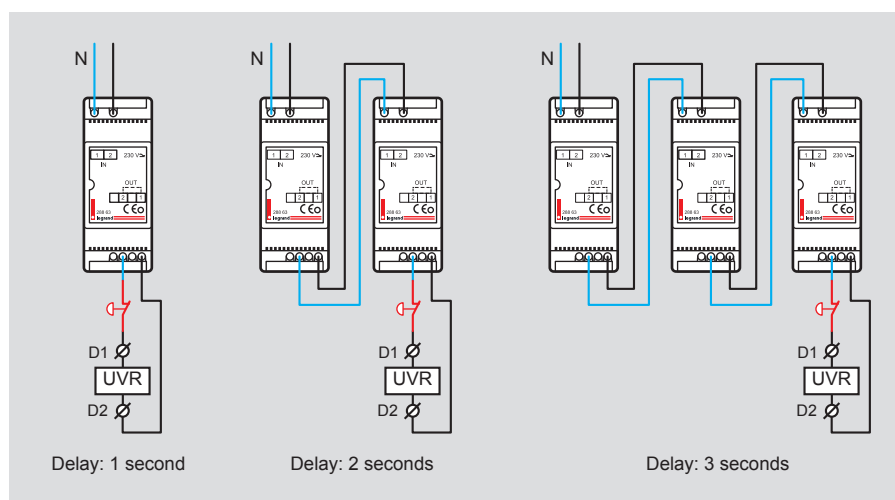
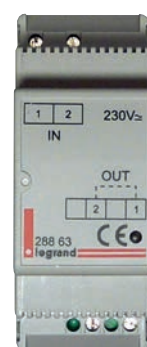

Dedicated external power supply

The external power supply provides continuous power to the DMX³ protection unit. Any other source that could be used instead of the external power supply may interfere with the operation of the protection unit, or even switch it off, thus voiding the DMX³ warranty.

This external power supply is required if the sum of the currents in the three phases is less than 100 A, or if there is less than 130 A in one phase and 0 A on the other two phases, or in the following cases: if the protection unit has the MODBUS communication option (Cat.No 0 288 05), or if the thermal memory, programmable contacts or logical discrimination are used. It is also necessary with MP4 protection units (beyond five tests) and MP6 for the test function.

Each external power supply is capable of powering one MP6 touch screen protection unit or up to four MP4 LCD screen protection units. However, it is not possible to power one MP6 touch screen protection unit and one MP4 LCD screen protection

unit with the same external power supply. This power module must itself be supplied with 24 Vdc or 24 Vac, for example, by installing one of the following devices upstream:

- Cat.No 4 130 96: 230 Vac/24 Vac safety transformer
- Cat.No 1 467 22: 115-230 Vac/24 Vdc stabilised power supply
- Cat.No 4 131 08: 230 Vac/24 Vdc filtered rectified power supply.

Particular care must be taken when connecting this external power supply to the DMX³ terminal block. A wiring reversal can damage the protection unit.

- Terminal H1 on the DMX³: terminal 4 of the power supply Cat.No 0288 06
- Terminal H2 on the DMX³: terminal 3 of the power supply Cat.No 0288 06



TECHNICAL CHARACTERISTICS

- Power supply voltage: 24 Vac/dc $\pm 10\%$
- Constant input power: 5 W/VA
- Output current: 250 mA

 Batteries located under the protection unit allow the information contained in the protection units to be consulted.

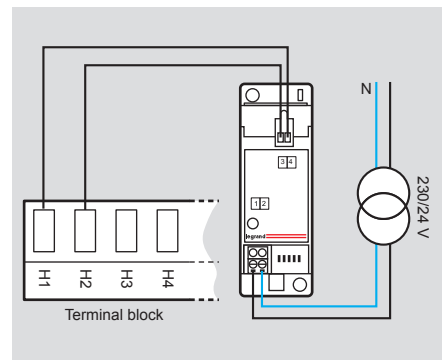

Local programmable relay

This local programmable relay is a standard feature for all circuit breakers equipped with a MP4 or MP6 protection unit.

This relay is programmed via the protection unit menu.

The dedicated external power supply Cat.No 0 288 06 is required for fault functions.

It provides remote feedback on the information or faults originating from the protection unit:

- device open
- device closed
- device tripped
- overload $I > 0.9 I_r$
- overload $I > 1.05 I_r$

- temperature of the protection unit $T > 75\text{ °C}$

- electrical fault (generic)
- thermal fault (I_r)
- magnetic fault (I_{sd})
- instantaneous fault (I_i)
- fixed protection fault (I_{cw})
- earth fault (I_g)
- overheating fault ($T > 95\text{ °C}$)
- test fault (test button/function)

This programmable contact is a volt-free changeover contact (4 A/230 Vac).

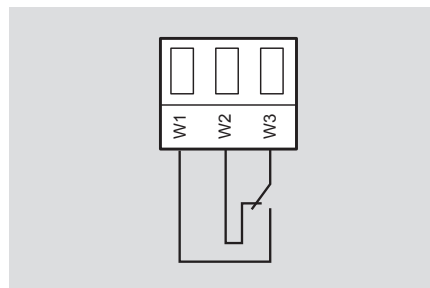
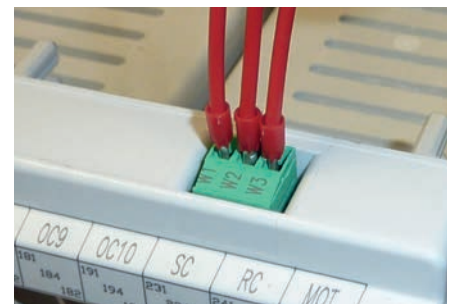

Programmable OUTPUT module

This local programmable output module is a standard feature for all circuit breakers equipped with a MP4 or MP6 protection unit.

Outputs are programmed via the protection unit menu.

The external power supply module Cat.No 0 288 06 is required to power the protection unit (see diagram opposite). 0 288 06 is required to power the protection unit (see diagram opposite).

The programmable functions are identical to the programmable relay. They provide remote feedback on the information or faults originating from the protection unit:

- device open
- device closed
- device tripped
- overload $I > 0.9 I_r$
- overload $I > 1.05 I_r$
- temperature of the protection unit $T > 75\text{ }^\circ\text{C}$
- electrical fault (generic)
- thermal fault (I_r)
- magnetic fault (I_{sd})
- instantaneous fault (I_i)

- fixed protection fault (I_{cw})
 - earth fault (I_g)
 - overheating fault ($T > 95\text{ }^\circ\text{C}$)
 - test fault (test button/function)
- They can be fixed or flashing as indicated below:

- None: instantaneous and fixed change, state changes at the same time as the selected parameter
- 1 s, 2 s, 3 s, 5 s, 10 s, 20 s, 30 s
- 1 min, 2 min, 5 min, 10 min, 20 min, 30 min
- Infinite: Instantaneous and fixed change, the return of the contact to the normal state must be made by a reset from the protection unit menu.

Programmable contacts are volt-free changeover contacts (8 A/230 Vac)



ELECTRICAL CHARACTERISTICS

- 24 Vac/dc $\pm 10\%$
- 8 W per module

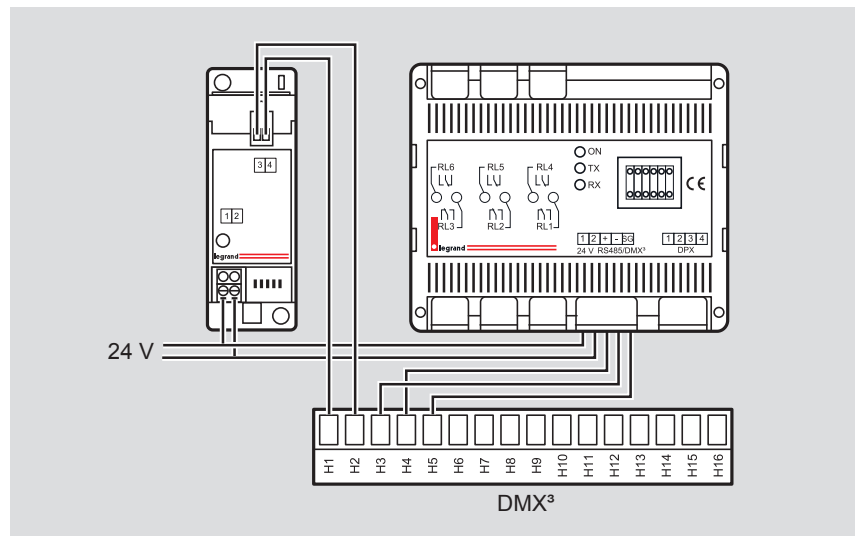

Rogowski coil for external neutral and earth protection



The use of the Rogowski coil requires a special adaptation of the circuit breaker. It must be ordered with this factory-fitted option, because it cannot be added later. This coil is used for the following functions:

- Protection against overload of the neutral when it is not broken by the DMX³
- Earth protection with the LSlg protection units and only with a system with an unbroken neutral

USE OF THE ROGOWSKI COIL ACCORDING TO THE PROTECTION UNIT

	MP4						MP6			
	LI		LSI		LSlg		LSI		LSlg	
	3P	4P	3P	4P	3P	4P	3P	4P	3P	4P
External neutral protection	✓	✗	✓	✗	✓	✗	✓	✗	✓	✗
External neutral protection (can be disabled) and earth protection	✗	✗	✗	✗	✓	✗	✗	✗	✓	✗
Earth protection - if no neutral	✗	✗	✗	✗	✗	✗	✗	✗	✗	✗

✓: Can be used ✗: Cannot be used

EXTERNAL NEUTRAL PROTECTION

This option is only available for 3-pole devices with MP4 and MP6 protection units. The coil is connected to the neutral, at the same level as the DMX³.

For the MP6 protection unit, a neutral voltage tap should be applied to the DMX³ terminal block.

The direction of current flow in the

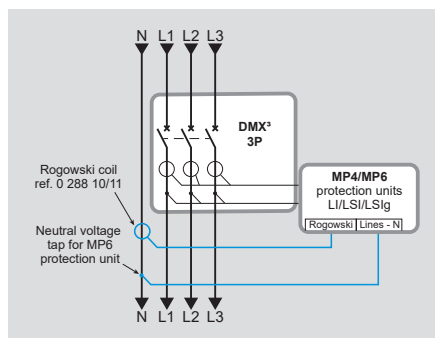

Rogowski coil must be respected (see product instructions).

The terminal block supplied with the coil should be connected to the terminal block of the electronic board of the protection unit. Whenever possible, the coil wire should be kept as far as possible from electromagnetic interference sources

(transformers, etc.) and from power conductors.

Check the correct setting of the protection unit.

EXTERNAL NEUTRAL AND EARTH PROTECTION

The "earth protection" function is different from a "residual current protection" function. As a reminder, the minimum setting of the earth protection is $I_g = 0.2 \times I_n$. The protection principle is of the RS (Residual Sensing) type. The earth fault current is calculated using the vector sum of the currents of the three phases. The SGR (Source Ground Return) and ZS (Zero Sequence) type protections are not usable. This option is available for 3-pole DMX³ air circuit breakers with unbroken neutral, equipped with MP4 or MP6 protection units, LSlg version.

The Rogowski coil is connected to the neutral, at the same level as the DMX³.

For the MP6 protection unit, a neutral voltage tap should be applied to the DMX³ terminal block.

External neutral protection against overloads is enabled at the factory, but can be disabled afterwards.

The direction of current flow in the

Rogowski coil must be respected (see product instructions).

The terminal block supplied with the coil should be connected to the terminal block of the electronic board of the protection unit. Whenever possible, the coil wire should be kept as far as possible from electromagnetic interference sources (transformers, etc.) and from power conductors.

Check the correct setting of the protection unit.

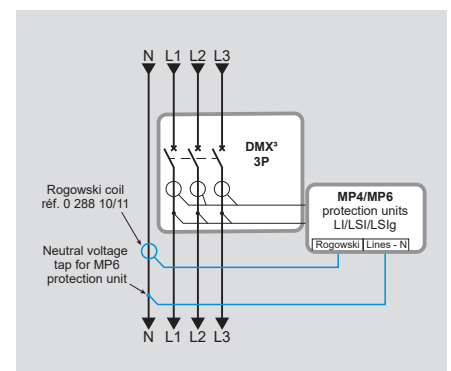

MECHANICAL ACCESSORIES

Characteristics

Lifting handles

Handles are sold in pairs. They are used to lift the device to extract a draw-out DMX³ from its base or to install a fixed DMX³ in an enclosure.

For safe operation, it is necessary to ensure correct insertion of the two handles, and be sure to use proper lifting equipment.

These handles are used exclusively for handling the DMX³.

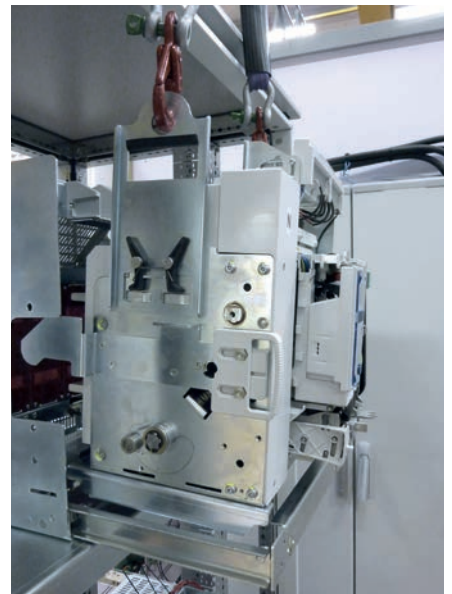

Placement of a draw-out DMX³ in its base

INSTALLING LIFTING HANDLES



INCORRECT

CORRECT



Placement of a fixed DMX³

Interlocking mechanism

The interlocking mechanism can mechanically lock multiple DMX³ devices together. It is used to create a supply inverter with two or three devices (A, B, C or D -see page 48-49).

There is one Cat.No for each DMX³ size, thus three Cat.Nos in total.

Only Legrand interlocking cables, referenced for the DMX³ (see below) must be mounted on the interlocking mechanisms.



Interlocking cables

Interlocking cables are used to mechanically connect the DMX³ via the interlocking mechanisms (see above).

They are available in seven standard lengths: 1 - 1.6 - 2.6 - 3 - 3.6 - 4 - 4.6 - 5.6 m.

The length should be chosen based on the location of the DMX³ in the enclosure. It is important to respect the minimum bend radius of 65 mm, and to ensure that throughout its length, it is fixed to the enclosure structure after mechanical adjustment of the system.



i For specific lengths, please contact Legrand Customer Service.

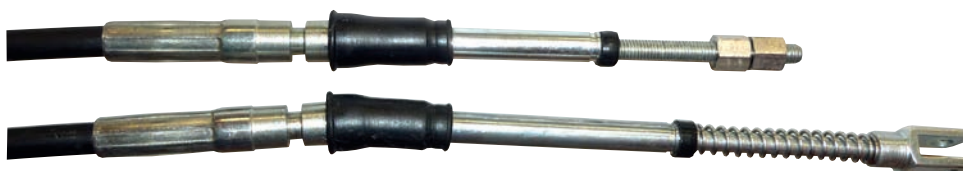

KEY LOCKING in "open" position

Locking in the "open" position prohibits the closure of the DMX³. This lock can be installed on fixed or draw-out devices (air circuit breaker or trip-free switch), size 2500, 4000 or 6300.

There are two types of lock: with a flat key (RONIS type) or with a star key (PROFALUX type).

To lock the DMX³, simply press the OFF button and turn the key a 1/4 turn clockwise.

To unlock the DMX³, simply turn the key a 1/4 turn anti-clockwise; the OFF button will revert to its original position.

The key can be removed when the lock is

in the "locked" position. This then renders the device inoperative.

The locking accessory includes two slots. It is possible to install either a single cylinder (with flat or star key) in either one of the two housings, in other words slots, or two cylinders (either two of the same type or one of each). In the latter case, only one of the keys is required to lock the DMX³.

It is possible to order specific cylinders or extra keys from the company STI* by specifying the cylinder number:

- flat key: ABA90GEL6149

- star key: HBA90GPS6149

However, it is necessary to order a lock kit in order to have different mounting accessories.

There is a kit for key locking in the "open" position, consisting of five identical cylinders with five corresponding flat keys and accessories (mounting rings and drive cams), and a kit consisting of five different cylinders and three different keys for creating several different combinations (see list on page 9).



Locking accessory Cat. No. 0288 28, equipped with a cylinder with a flat key Cat.No 0 288 31

Locking accessory Cat. No. 0288 28, equipped with a cylinder with a star key Cat.No 0 288 30

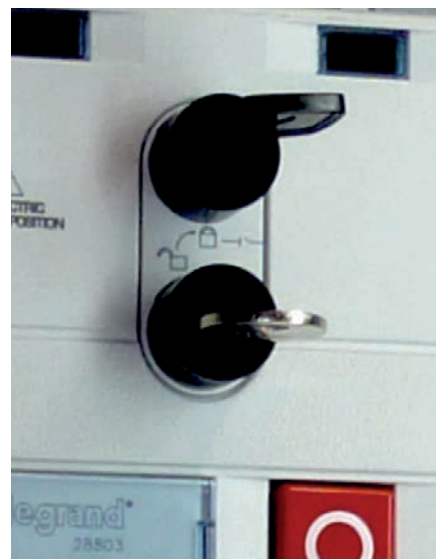

Locking accessory equipped with two cylinders of different types

i The two available slots on the key locks provide the same locking.

Key locking in "Plugged IN/TEST/ Drawn OUT" position

This accessory permits locking in the plugged in, test or drawn out positions. A part supplied with the kit is used to prevent locking in a plugged in position. It is always preferable to install this part, thus preventing locking in a "plugged in" position, and remove it later if necessary.

To lock the draw-out DMX³ in a "test" position and/or in a "drawn out" position, turn the key a 1/4 turn clockwise after making sure that the handle is removed from the plug-in system, and that its slot is closed.

In a "locked" position, the key is free. It is then possible to put the unit out of use by removing it.

To unlock the DMX³, to be able to plug it in, simply turn the key a 1/4 turn anti-clockwise, thus releasing the blanking system for the handle.

There are two types of lock:

- with a flat key (RONIS type)

- with a star key (PROFALUX type)

It is possible to order specific cylinders or extra keys from the company STI* by specifying the cylinder number:

- flat key: ABA90GEL6149

- star key: HBA90GPS6149

However, it is necessary to order a lock kit in order to have different mounting accessories.



Locking accessory Cat.No 0288 32/33 equipped with two cylinders of different types



i The two available slots on the key locks provide the same locking.

*  Serv Trayou Interverrouillage (<http://www.servtrayou.com>)

Door lock

This lock is used to prevent the opening of the faceplate or door when the draw-out DMX³ is in a "plugged in" position. The faceplate can be opened in the "drawn out" position.

The faceplate can be closed in three positions with the DMX³ closed or open.

The lock can be installed on the left or right respectively, for a faceplate with left or right hinges.

The Cat.No includes all the accessories for mounting the fixed part on to the DMX³, and the movable part on the door or on the faceplate.

The faceplates for DMX³ used in XL³ 4000/6300 enclosures are already equipped with the locking system.



Rating locating pin

When several draw-out DMX³ are present in the same panel, the rating locating pin ensures that the incorrect DMX³ cannot be installed in a base. If the size and number of poles can be identical, the settings, wear, marking and accessories can be different. There are nine possible coding combinations.



Operation counter

The operation counter is used to display the number of "opening/closing/spring charging" cycles performed by the product on the front of the DMX³.

This counter can be installed on all air circuit breakers and trip-free switches in the DMX³ range.

It comes with the display "99995". It cannot be reset manually.

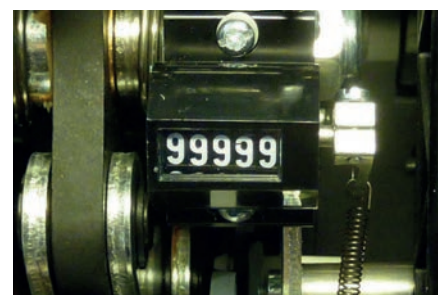

Padlocking in "Drawn out" position

This safety accessory can take two padlocks with a diameter between 5 and 8 mm. When at least one padlock is installed, it prevents the safety shutters from being opened and, when inserting a device, locks the device in the "drawn out" position by a physical end stop.

Once in place in the base, the DMX³ cannot be set to the "test" position.



Padlocking in "open" position

This accessory for locking in "open" position prevents the closure of the DMX³. It can be installed on fixed or draw-out devices (air circuit breaker or trip-free switch), size 2500, 4000 or 6300. This accessory is mounted instead of the key lock for locking in the open position (see p. 30), it is therefore impossible to have a key lock and a padlock for locking in the open position on the same device. It can take up to three padlocks with a diameter between 5 and 8 mm. One single padlock installed ensures locking. To padlock the DMX³, it is first necessary to press and hold the OFF button and push down on the metal part.

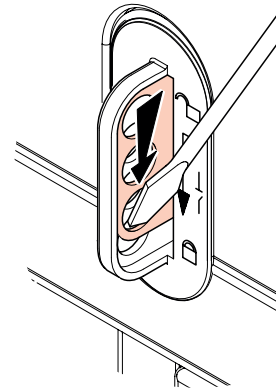

Padlocking the ON/OFF buttons

This device is used to lock out physical access to the ON/OFF buttons. It is possible to lock both buttons at the same time, or only one of them. This device can only take one padlock with a diameter of 4 mm

i The Legrand offer includes two safety padlocks:
 Cat.No 4 063 13 (5 mm diameter)
 Cat.No 0 227 97 (6 mm diameter)

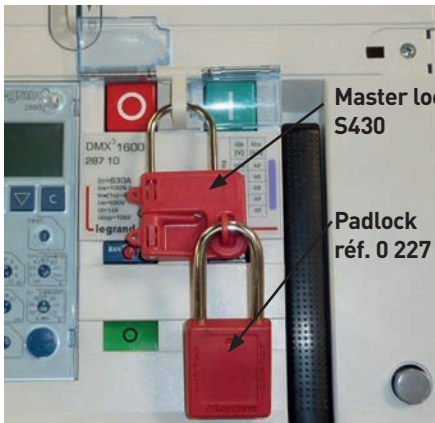

Padlocking the ON button only



Padlocking the OFF button only



Padlocking the ON and OFF buttons

Empty base

Empty bases are used to convert a fixed DMX³ to draw-out device by equipping it with the appropriate conversion kit (see below). Empty bases are supplied without accessories and without the auxiliary terminal block (see parts list).



Empty base for DMX³ - Size 6300 - 4-pole - Cat.No 0 289 14 and terminal block Cat. No. 0 290 12

Fixed to draw-out conversion kits

Associated with an empty base, these kits are used to convert a fixed device to a draw-out device. It is possible to order a DMX³ device factory fitted with a conversion kit without the base. They include all the accessories required for conversion, such as the plug-in mechanism, handles, actuator, etc.

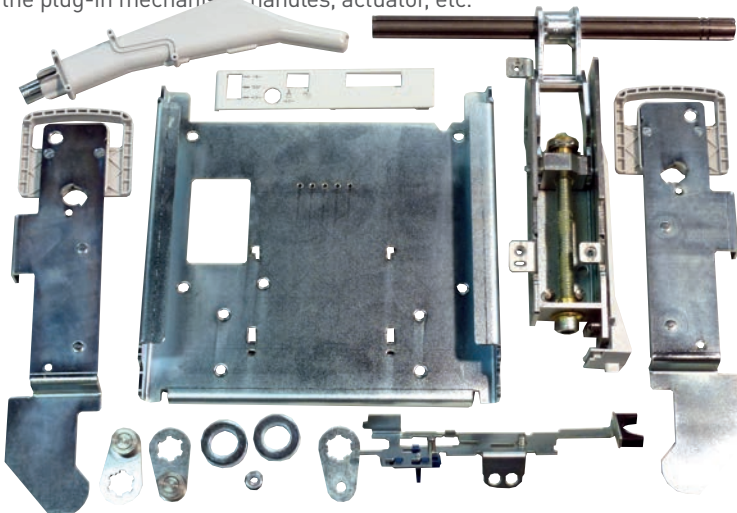

CONNECTION ACCESSORIES

Characteristics

The various connection accessories available for the entire DMX³ range offer a wide choice of options, which can be easily adjusted according to the desired configurations.

The screws needed for assembly of the different accessories are supplied with each set. Tightening torques to be applied are shown in the instructions supplied with the products.

The screws used for fixing busbars to the accessories are not supplied; these remain the responsibility of the panel builder.

Tightening torques for busbar fixing screws depend on the diameter and the quality thereof. It is therefore necessary to consult the manufacturer of the screws used.

DMX³ FIXED VERSION

- Size 2500: six possible configurations for rear terminals - horizontal, vertical, flat, horizontal spreaders, vertical spreaders and flat spreaders.

- Size 4000 and 6300: three possible configurations for rear terminals - horizontal, vertical and flat.

The insulated shields Cat.No 0 288 98/99 are for sizes 2500, 4000 and 6300. They cannot be mounted when the DMX³ is equipped with spreaders.

■ Horizontal connection

Fixed DMX³ are devices equipped as standard with rear terminals with horizontal connection plates (see next page). Copper or aluminium busbars can be connected directly to them.

It is possible to install insulated shields between the poles.

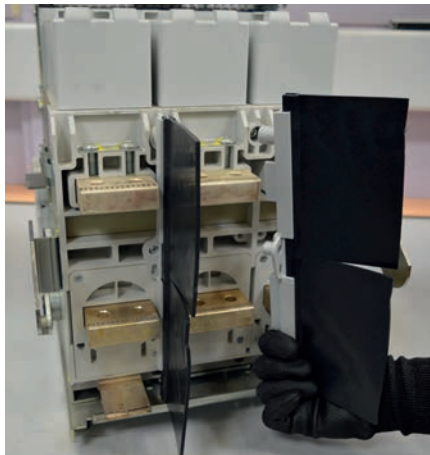

The insulated shields are high enough to isolate both the upstream and downstream terminals.

■ Flat connection

Flat connection accessories attach directly to horizontal connection plates integrated in the fixed version DMX³.

Copper or aluminium busbars bolt directly to the flat connection plates, such as the ends of the upstream vertical busbars, for example.

The flat connection kit is required for use with DMX³/SCP incomer connection kits (see page 42).

It is possible to install insulated shields between the poles. The dividers are high enough to isolate both the upstream and downstream terminals equipped with flat connection accessories.

Size 6300 DMX³ with their doubled poles, the kits for flat connections must be ordered in pairs.

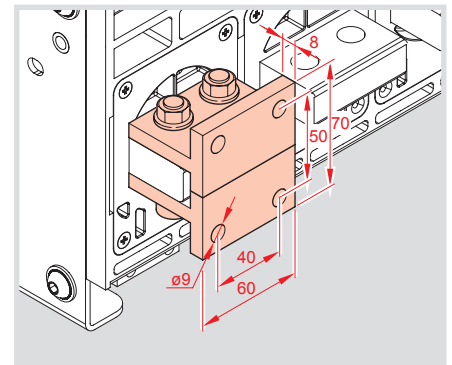

Flat connection accessory for the DMX³ size 2500

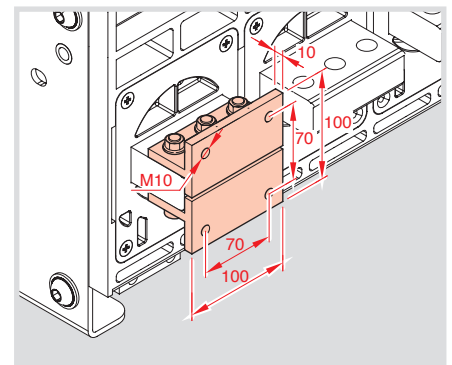

Flat connection accessory for DMX³ size 4000 and 6300

i The choice of connection accessories must be made according to the size and number of bars used by the poles.

FIXED DMX ³	3-POLE	4-POLE
Size 2500		
Size 4000		
Size 6300		

Rear terminals for horizontal connections integrated on the fixed DMX³

■ Vertical connection

For DMX³ sizes 2500, 4000 and 6300, the vertical connection kit is fixed. It is mounted on the flat connection kit.

Copper or aluminium busbars bolt directly to the vertical plates, such as the connections to transfer busbars for example.

It is possible to install insulated shields between the poles. The insulated shields are high enough to isolate both the upstream and downstream terminals equipped with vertical connection kits.

Size 6300 DMX³ have double poles, hence the vertical connection kits must be ordered in pairs.

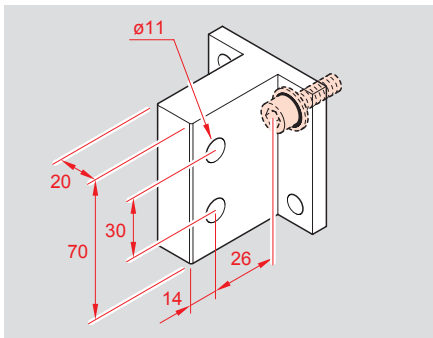

Vertical connection accessory for fixed DMX³ size 2500

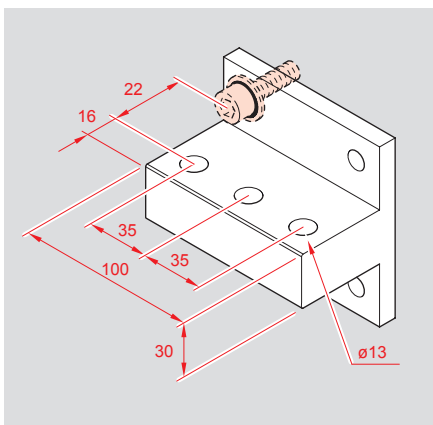

Orientable connection accessory for DMX³ size 4000 and 6300

■ Connections with flat, vertical and horizontal spreaders

Only size 2500 fixed DMX³ devices can be equipped with spreaders. The new fixing centre obtained thus increases from 85 mm to 116.5 mm (3P) or 106 mm (4P).

It is not possible to install separation dividers when the DMX³ is equipped with spreaders.

Copper or aluminium busbars are connected directly to the spreaders.

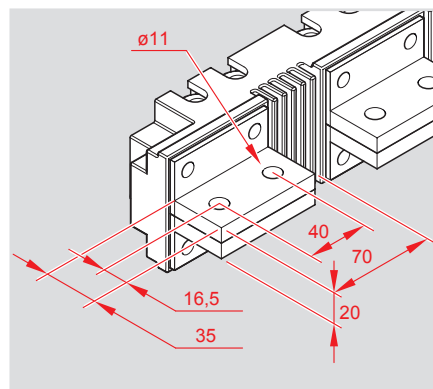
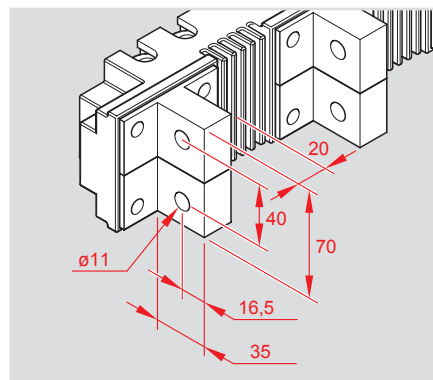
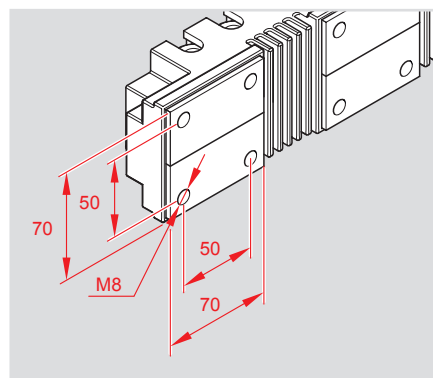

Spreaders for fixed DMX³ size 2500

DMX³ DRAW-OUT VERSION

The rear terminals and connection accessories of the draw-out DMX³ allow 3 connection configurations: flat, horizontal and vertical.

Insulated shield (Cat.No 0 288 18/19) can be installed between each pole on all draw-out devices. The dividers are high enough to isolate both the upstream and downstream terminals.

■ Flat connection

The draw-out DMX³ is equipped as standard (without any other accessories) with flat connection plates (see next page).

Copper or aluminium busbars can be connected directly to them.

■ Horizontal connection

For DMX³ sizes 2500, 4000 and 6300, the rear terminals can be oriented horizontally or vertically.

Copper or aluminium busbars can be fixed directly to these accessories, such as the connections to transfer busbars for example.

Size 6300 DMX³ have double poles, hence the connection kits must be ordered in pairs.

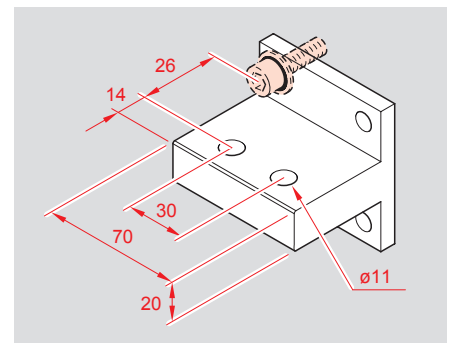

Orientable connection accessory for draw-out DMX³ size 2500.

DRAW-OUT DMX ³	3-POLE	4-POLE
Size 2500		
Size 4000		
Size 6300		

Rear terminals for flat connections integrated on the draw-out DMX³

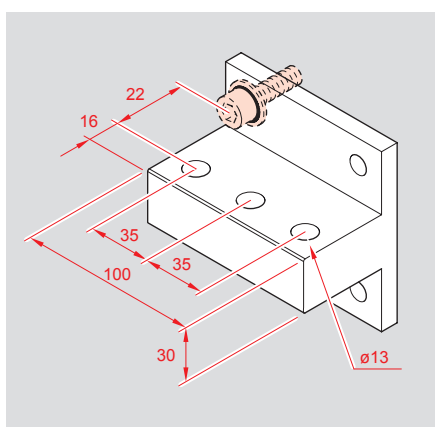

Orientable connection accessory for draw-out DMX³ size 4000 and 6300

■ Vertical connection

For DMX³ size 2500, 4000 and 6300, the same orientable rear terminals are used as for the horizontal connection.

Copper or aluminium busbars can be fixed directly to these accessories, such as the connections to transfer busbars for example.

Size 6300 DMX³ have double poles, hence the connection kits must be ordered in pairs.

DMX³ INSTALLATION IN ENCLOSURES

MOUNTING

XL³ 4000 and 6300 enclosures have equipment specifically dedicated to mounting DMX³ devices (see table below). The possible installation configurations are numerous. Installation is facilitated by the use of XL Pro³ software.

It is also possible to install DMX³ in "OEM" or locally built enclosures. In this case, it is the panel builder's responsibility to adapt accessories for the correct implementation of the DMX³, taking into account the significant weight of these products. In order to fix DMX³ devices correctly on their plate, they have M8 inserts (four for DMX³ fixed and draw-out versions sizes 2500 and 400 and draw-out versions size 6300, eight for DMX³ fixed versions size 6300).

! The metal structure of the DMX³ must be connected to the enclosure ground. The fixing points cannot be considered as connection points.

DIMENSIONS FOR MOUNTING IN ENCLOSURES OTHER THAN XL³

Fixed version

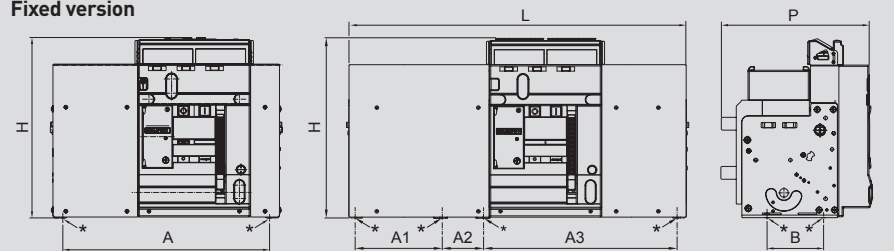

* M8 fixing points

Dimensions (mm)	Size 2500		Size 4000		Size 6300		
	3P	4P	3P	4P	3P	4P	
Overall	H	419	419	419	419	419	
	W	273	358	408	538	797	1057
	D ¹	354	354	354	354	354	354
Fixing centres	A	215	300	350	480	A1: 183 A2: 114 A3: 443	A1: 443 A2: 114 A3: 443
	B	132	132	132	132	132	132
	Weight (kg)						
Circuit breaker		41	48	59	76	118	152
	Switch		45	57		114	146

Draw-out version

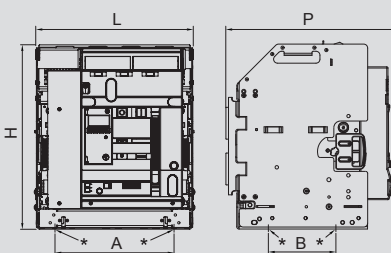

* M8 fixing points

Dimensions (mm)	Size 2500		Size 4000		Size 6300		
	3P	4P	3P	4P	3P	4P	
Overall	H	473	473	473	473	473	
	W	327	412	425	555	804	1064
	D ¹	433	433	433	433	433	433
Fixing centres	A	220	305	318	448	448	708
	B	170	170	170	170	170	170
Weight (kg)	Circuit breaker	77	94	108	137	225	274
	Switch	75	91	106	134	212	268

1: Without accessories and in "plugged in" position for draw-out versions

XL ³ EQUIPMENT FOR THE DMX ³	SIZE 2500		SIZE 4000				SIZE 6300		
	3P/4P		3P		4P		3P/4P		
	FIXED	DRAW-OUT	FIXED	DRAW-OUT	FIXED	DRAW-OUT	FIXED	DRAW-OUT	
XL ³ 4000 24 modules	Plate	0 207 51	0 207 53	0 207 51	0 207 53	0 207 51	0 207 53	-	-
	Faceplate	0 209 38				0 209 39		-	
XL ³ 4000 36 modules	Plate	0 207 52	0 207 54	0 207 52	0 207 54	0 207 52	0 207 54	-	-
	Faceplate	0 209 48						-	
XL ³ 6300	Plate							0 211 38	0 211 40
	Faceplate							0 211 39	

For enclosures different from XL³, it is necessary to respect the installation position of the DMX³ in terms of depth relative to its faceplate. Ensure that the space between the DMX³ and the faceplate is enough, and that the front panel of the DMX³ protrudes slightly to be able to install the IP40 frame.

Faceplates for XL³ 4000 and XL³ 6300 enclosures are pre-drilled to attach the

IP40 frames. For other enclosures, follow the drilling plan below according to the type of device.

When installing a DMX³ in an enclosure, it is imperative that a safety gap is provided down the sides of the arc chambers. In fact, during an arc blast, it is possible for the air to ionize and cause a short circuit between nearby bare conductors.

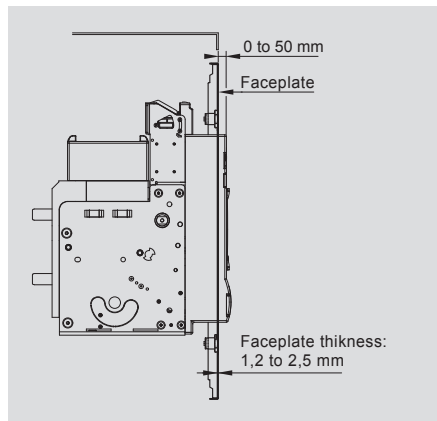

Position of a fixed DMX³ in relation to its faceplate

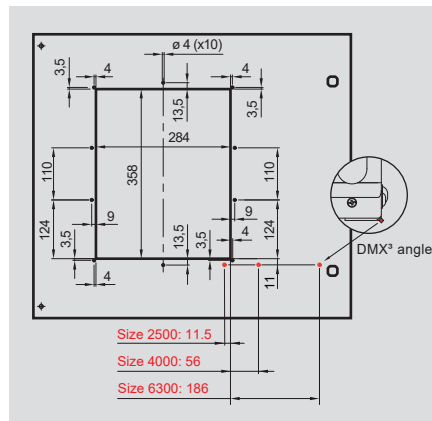

Drill hole drawing of the faceplate for a fixed DMX³

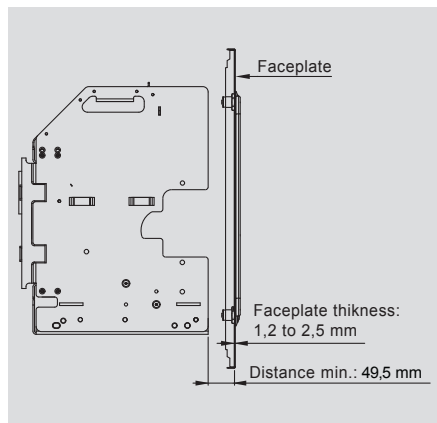

Position of a draw-out DMX³ in relation to its faceplate

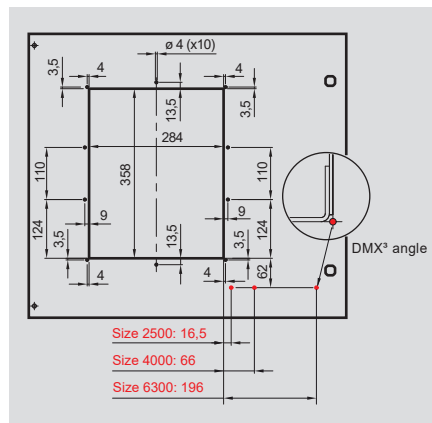

Drill hole drawing of the faceplate for a draw-out DMX³

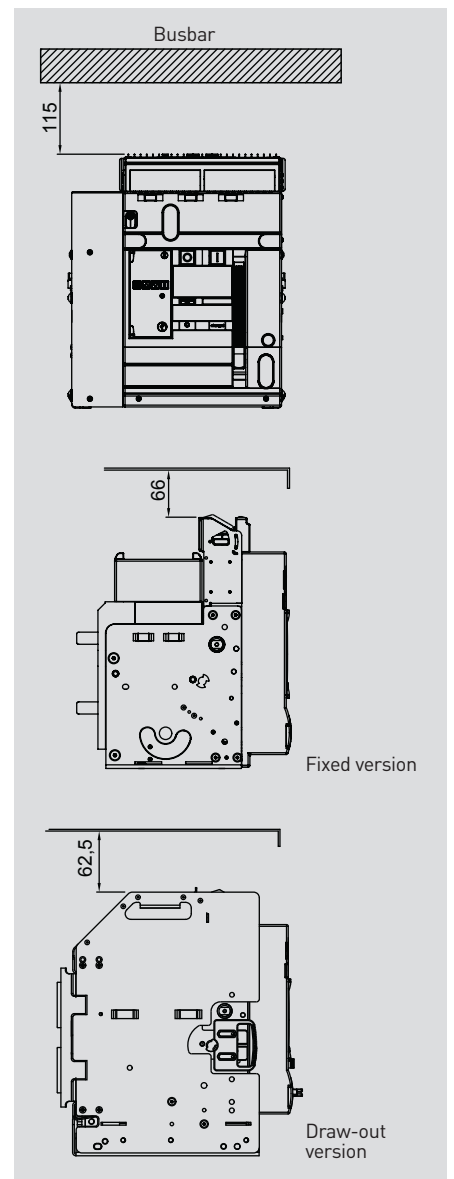

It is recommended to leave a space of 115 mm between the top of the DMX³ and the busbar and to leave a space of 66 mm for fixed versions, or 62.5 mm for draw-out versions, between the top of the DMX³ and any metal element (divider, structure, etc.)



All devices come with an IP 40 frame which is installed on the faceplate to prevent access to live parts on the front panel

DMX³ INSTALLATION IN ENCLOSURES

CONNECTION

Dedicated kits facilitate connection of the DMX³ upstream terminals to an incomer for Legrand SCP prefabricated trunking. These kits are mounted on DMX³ size 2500 devices from 1600 to 2500 A, fixed or draw-out versions, 3-pole or 4 pole. They require the use of flat connection accessories (see page 10-11).

SCP LINK CONNECTION KITS

DMX ³	FIXED	DRAW-OUT
1600 A	4 043 00	4 043 03
2000 A	4 043 01	4 043 04
2500 A	4 043 02	-



Kit for connection between a draw-out DMX³ size 2500 and an incoming SCP

Prefabricated connection kits are also provided for the DMX³ downstream connection to aluminium transfer busbars (with 75 mm fixing centres) positioned above or below the DMX³. These pre-formed and pre-drilled copper kits are available for size 2500 devices up to 2000 A and size 4000 for up to 3200 A, fixed and draw-out versions, and for supply inverters.



Kit for connection between a fixed DMX³ size 2500 aluminium transfer busbars



Kit for connection between a draw-out DMX³ size 2500 inverter and aluminium transfer busbars

KITS FOR CONNECTION TO TRANSFER BUSBARS

CONFIGURATION	DMX ³			
	≤ 1600 A	SIZE 2500 ≤ 2000 A	≤ 2500 A	SIZE 4000 UP TO 3200 A
1 fixed DMX ³	4 043 68	-	-	-
	-	4 043 64	-	4 043 60
2 fixed DMX ³ as supply inverters	4 043 69	-	-	-
	-	4 043 65	-	4 043 61
1 draw out DMX ³	4 043 70	-	-	-
	-	-	4 043 66	4 043 62
2 draw-out DMX ³ as supply inverters	4 043 71	-	-	-
	-	-	4 043 67	4 043 63

The DMX³ structure must be connected to the enclosure ground. The fixing points of the DMX³ cannot be considered as connection points.



Connection point on the fixed DMX³



Connection point on the draw-out base

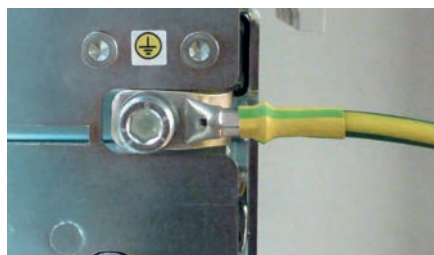

Busbar supports must be installed at a certain distance from the DMX³ connection plates. Supports must keep the busbars in position in relation to each other during an electrodynamic force caused by a short circuit. This distance depends on the I_{sc} at the point at which the DMX³ is installed. DMX³ connection plates cannot withstand the mechanical stresses associated with the busbars or the weight of the cables.

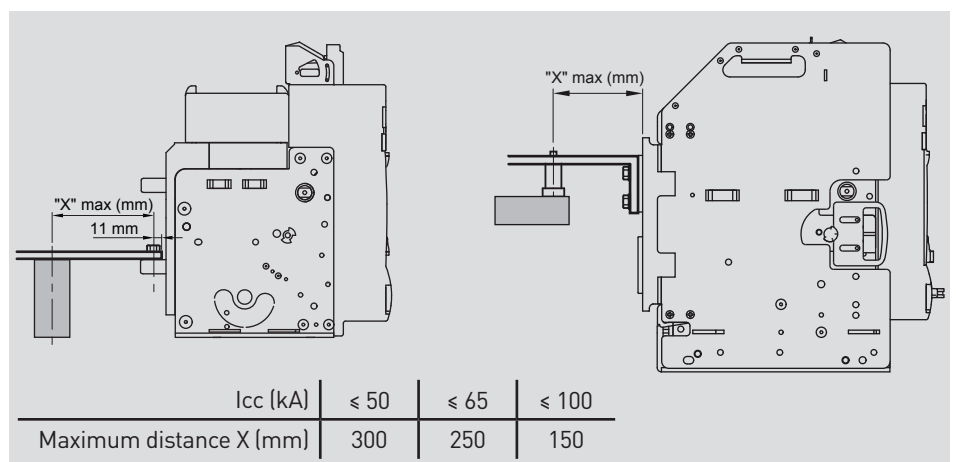

i For more information on the use of Legrand electric distribution enclosures, refer to the XL³ 4000/6300 workshop specifications available at www.legrand.com.

SUPPLY INVERTERS

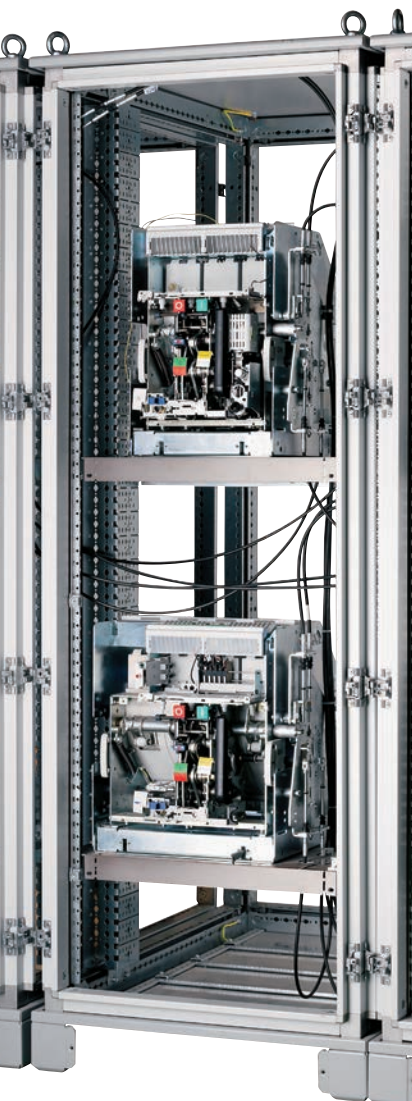

All DMX³ devices can be equipped with an interlocking kit that ensures "mechanical safety" when used as supply inverters. Connections between the DMX³ devices are provided by a system of cables and mechanisms attached to each device. This system can be adapted for use across the entire DMX³ range (air circuit breakers and trip-free switches, 3 and 4-pole, sizes 2500, 4000 and 6300, fixed or draw-out versions from 50 kA to 100 kA) and offers the potential to combine different products from the range. The interlocking mechanism is used to create supply inverters up to a maximum of three devices.

There are four possible types of interlocking.

■ Type A

Ability to close one of the two devices only. Using two interlocking cables.

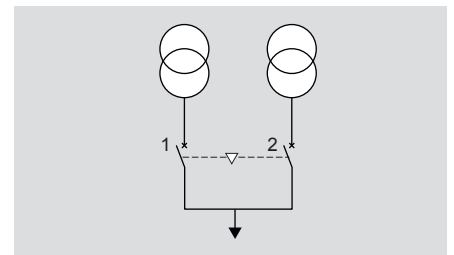

DMX ³ NO. 1	DMX ³ NO. 2
0	0
0	1
1	0

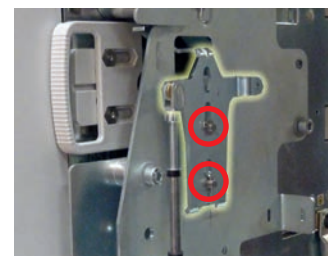

The "Z" parts of both devices should be installed for translational motion, as in the photo

■ Type B

Ability to close device only out of the three available.

Using six interlocking cables.

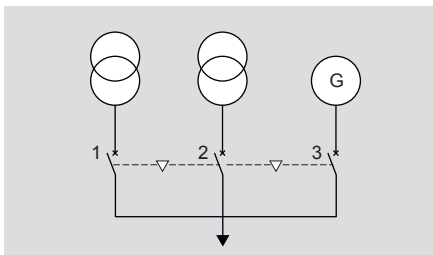

DMX ³ NO. 1	DMX ³ NO. 2	DMX ³ NO. 3
0	0	0
1	0	0
0	1	0
0	0	1



The "Z" parts of all three devices should be installed for translational motion, as in the photo

■ Type C

Ability to close one device only out of the three available.

Ability to close two of the three devices available, without being able to close the third device.

Using six interlocking cables.

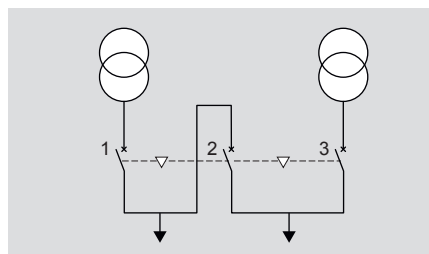

DMX ³ NO. 1	DMX ³ NO. 2	DMX ³ NO. 3
0	0	0
1	0	0
0	1	0
0	0	1
0	1	1
1	0	1
1	1	0



The "Z" parts of all three devices should be installed for rotation, as in the photo

■ Type D

Ability to close one device only out of the three available.

Ability to close two predetermined devices (e.g. No. 1 and No. 2) without being able to close the third (e.g. No. 3).

Ability to close one specific device only (e.g. No. 3) without being able to close the other two (e.g. No. 1 and No. 2).

Using four interlocking cables.

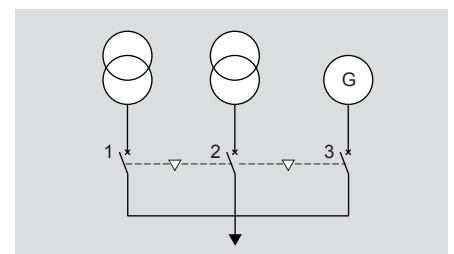

DMX ³ NO. 1	DMX ³ NO. 2	DMX ³ NO. 3
0	0	0
1	0	0
0	1	0
0	0	1
1	1	0

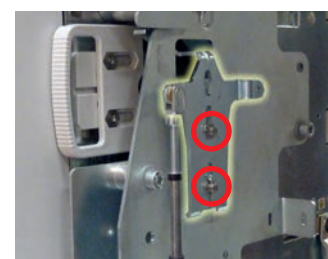

The "Z" parts of all three devices should be installed for translational motion, as in the photo

SUPPLY INVERTERS

INSTALLATION OF SUPPLY INVERTERS

Due to the presence of flexible connections ensuring mechanical interlocking, a supply inverter created using DMX³ devices must be installed in the same enclosure, or in a set of side-by-side enclosures.

It is possible to use up to 2 DMX³ (size 2500 and 4000) vertically in the same XL³ 4000 enclosure, and a single DMX³ size 6300 in an XL³ 6300 enclosure.

On the same horizontal plane, two DMX³ devices, equipped with supply inverters may be located within a maximum of 4 meters.

SUPPLY INVERTER WITH DMX³ TYPE A AND C

An inverter with two sources can be controlled using the ATS reference 4 226 80 - 4 226 82 - 4 226 83, provided that both devices are equipped with at least one opening coil, a closing coil and motor operator. The wiring diagrams are available in E-catalog (LE09480AA-EN and LE09887AA-FR, except 4 226 83).

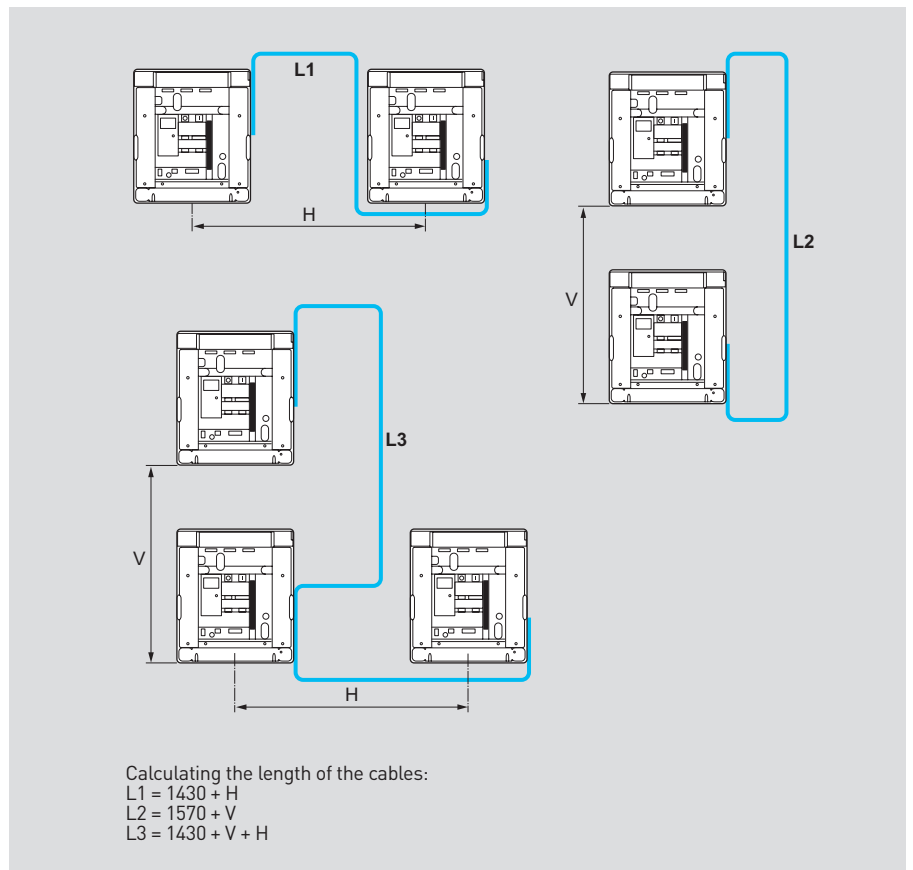

INVERTER WITH THREE DMX³ (TYPES B AND D)

It is necessary to equip the devices with at least one opening coil, a closing coil and a motor operator.

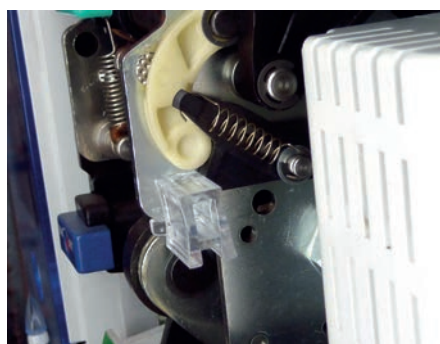

Accessory for correct adjustment of the supply inverter connecting rod

i After adjusting and tightening the different elements of the mechanical interlock, you should fix the interlocking cables along their entire length to the structure of the enclosure.

+ Up to 3 sources (5 devices) can be managed using the ATS automation case 4 226 84. For more information, please contact Legrand Customer Service.

+ The new ATS range includes 3 types of control unit, depending on the desired service level and the complexity of the installation. The new control units can be used to set the conditions for supply inversion, switching a generator on or off.



ORDERING AND DELIVERY STATUS OF THE DMX³

A DMX³ air circuit breaker cannot be ordered without a protection unit since the protection unit has to be programmed according to the circuit breaker and the desired options.

Using XLPro³ software, it is possible to generate a purchase order in Word® format. For further details concerning a DMX³ order, please contact your local Legrand sales office.

All electrical and mechanical accessories can be ordered and installed after delivery of the product.

For factory-fitted accessories and options, please see the table on the next page.

Order ACB DMX ³		Rate for : 2021-01																																									
Order n° :		Customer code :																																									
Please send this form to your usual commercial/sales contact																																											
Construction site informations :																																											
Price offer n° :		Date :																																									
Site: test		Building name :																																									
Panel : Nouveau tableau 1		Building type :																																									
Sales representative:		Building address :																																									
Manager :																																											
Name :		Address :																																									
Phone number/Email :																																											
Wholesaler		Delivery (if different address)																																									
Name :		Company name :																																									
Address :		Name :																																									
		Address :																																									
		Tel. n° / Email :																																									
900185 : ACB DMX ³ factory assembled																																											
<table border="1"> <thead> <tr> <th>Manufacturer</th> <th>Description</th> <th>Reference</th> <th>Quantity</th> </tr> </thead> <tbody> <tr> <td>Legrand</td> <td>ACB DMX³ 2500-N 4P 2500A 50kA Draw-out</td> <td>028736</td> <td>1</td> </tr> <tr> <td>Legrand</td> <td>DMX³ protection unit MP4 LSI</td> <td>028801</td> <td>1</td> </tr> <tr> <td>Legrand</td> <td>Communication option for DMX³ protection unit</td> <td>028805</td> <td>1</td> </tr> <tr> <td>Legrand</td> <td>External auxiliary supply 12V dc, primary 24V</td> <td>028806</td> <td>1</td> </tr> <tr> <td>Legrand</td> <td>Motor operator 230V ac/dc</td> <td>028837</td> <td>1</td> </tr> <tr> <td>Legrand</td> <td>Closing coil 220-240V ac/dc</td> <td>028844</td> <td>1</td> </tr> <tr> <td>Legrand</td> <td>Shunt trip 220-240V A.C./D.C.</td> <td>028851</td> <td>1</td> </tr> <tr> <td></td> <td></td> <td></td> <td></td> </tr> <tr> <td></td> <td></td> <td></td> <td></td> </tr> </tbody> </table>				Manufacturer	Description	Reference	Quantity	Legrand	ACB DMX ³ 2500-N 4P 2500A 50kA Draw-out	028736	1	Legrand	DMX ³ protection unit MP4 LSI	028801	1	Legrand	Communication option for DMX ³ protection unit	028805	1	Legrand	External auxiliary supply 12V dc, primary 24V	028806	1	Legrand	Motor operator 230V ac/dc	028837	1	Legrand	Closing coil 220-240V ac/dc	028844	1	Legrand	Shunt trip 220-240V A.C./D.C.	028851	1								
Manufacturer	Description	Reference	Quantity																																								
Legrand	ACB DMX ³ 2500-N 4P 2500A 50kA Draw-out	028736	1																																								
Legrand	DMX ³ protection unit MP4 LSI	028801	1																																								
Legrand	Communication option for DMX ³ protection unit	028805	1																																								
Legrand	External auxiliary supply 12V dc, primary 24V	028806	1																																								
Legrand	Motor operator 230V ac/dc	028837	1																																								
Legrand	Closing coil 220-240V ac/dc	028844	1																																								
Legrand	Shunt trip 220-240V A.C./D.C.	028851	1																																								
Select 1 language package for the protection unit:																																											
English / Italian / Français	<input checked="" type="checkbox"/>	English / French	<input type="checkbox"/>																																								
English / Russian	<input type="checkbox"/>	English / Spanish / Portuguese	<input type="checkbox"/>																																								
English / Chinese	<input type="checkbox"/>																																										
Quantity of ACB DMX ³ identical : 1																																											
Total value :																																											

Depending on the accessories ordered, the table below indicates whether they will be supplied assembled or not. Depending on the assembly centre and/or the contracts, the factory configuration of the DMX³ may vary.

Check the configuration of the DMX³ carefully to ensure you order all the accessories required for correct operation.

ACCESSORIES		ASSEMBLY STATE	
CAT. NOS.	DESCRIPTION	FACTORY ASSEMBLED	DETAILS
0 288 00 0 288 01 0 288 02 0 288 03 0 288 04	Protection unit	YES	Protection units are factory installed and configured with factory settings (see the guides for the relevant protection unit). The batteries and sealing kit are supplied but not pre-installed (they are delivered in a separate box).
0 288 05	MODBUS communication option (RS485)	YES	The circuit breaker must be factory configured in order to integrate the communication option. The Y4262 guide, specific to communication, is supplied with the circuit breaker.
0 288 06	External power supply	NO	This accessory is not integrated on or in the air circuit breaker. It is fixed on a modular rail.
0 288 09	Neutral on right-hand side (L1-L2-L3-N)	YES	The air circuit breaker must be configured at the factory in order to have the neutral positioned on the right. With this option, a special marking is added to the front panel, and the adhesive label "N" is placed in front of the corresponding pole, on the right.
0 288 10 0 288 11	External neutral	NO	The air circuit breaker must be factory configured in order to protect an external neutral. A Rogowski coil is supplied with the circuit breaker and must be connected to the protection unit terminal block.
0 288 12	Programmable output module	NO	This accessory is not integrated on or in the air circuit breaker. It is fixed on a modular rail.
0 288 13	Plugged in/test/drawn out position signalling contact	NO	After ordering, this accessory comes (unmounted) with the DMX ³ .
0 288 14	Spring charged signalling contact and ready to close signalling contact	YES	This accessory attaches to the inside of the DMX ³ and is connected to the SC and RC terminal block.
0 288 15	Additional auxiliary contact	YES	This accessory attaches to the inside of the DMX ³ and is connected to the OC5/6/7/8/9/10 terminal block.
0 288 16	Signalling contact	YES	This accessory attaches to the inside of the DMX ³ , on the corresponding coils and is connected to the C UVR/C ST/C CC terminal block.
0 288 20	Door lock	NO	After ordering, this accessory comes (unmounted) with the DMX ³ .
0 288 21	Padlocking in "open" position	YES	This accessory attaches to the inside of the DMX ³ .
0 288 23	Operation counter	YES	This accessory attaches to the inside of the DMX ³ .

ORDERING AND DELIVERY STATUS OF THE DMX³

ACCESSORIES		ASSEMBLY STATE	
CAT. NOS.	DESCRIPTION	FACTORY ASSEMBLED	DETAILS
0 288 24	Button padlock	YES	This accessory attaches to the outside of the DMX ³ .
0 288 25	Rating locating pin	YES	This accessory attaches under the DMX ³ and in the base.
0 288 26	Padlock for safety shutters	NO	After ordering, this accessory comes (unmounted) with the DMX ³ .
0 288 28 0 288 30 0 288 31	Key lock for locking in open position	YES	These accessories attach to the inside of the DMX ³ .
0 288 29	Set of 5 cylinders and flat keys	NO	After ordering, this accessory comes (unmounted) with the DMX ³ .
0 288 32 0 288 33	Key lock for locking in "plugged in/test/drawn out" position	PARTIALLY	These accessories are mounted on the handle support. This set is supplied unassembled on the DMX ³ .
0 288 34 to 0 288 40	Motor operator	YES	This accessory attaches to the inside of the DMX ³ and is connected to the MOT terminal block.
0 288 41 to 0 288 61	Closing coils	YES	This accessory attaches to the inside of the DMX ³ and is connected to the UVR/ST/CC terminal block.
0 288 48 à 0 288 52	Current shunt trip	YES	This accessory attaches to the inside of the DMX ³ and is connected to the UVR/ST/CC terminal block.
0 288 55 à 0 288 59	Undervoltage releases	YES	This accessory attaches to the inside of the DMX ³ and is connected to the UVR/ST/CC terminal block.
0 288 62 0 288 63	Delay module	NO	This accessory is not integrated on or in the air circuit breaker. It is fixed on a modular rail.
0 288 64 0 288 65 0 288 66	Interlocking mechanism	PARTIALLY	All accessories are attached to the DMX ³ . Only one part, used to determine the type of inverter (A/B/C/D) is supplied unassembled.
0 288 79	Transportation handle	NO	After ordering, this accessory comes with the DMX ³ .
0 288 38 0 288 39 0 288 80 to 0 288 97	Rear terminals	NO	After ordering, the accessories come (unmounted) with the DMX ³ .
0 288 86 to 0 288 91	Spreaders	NO	After ordering, the accessories come (unmounted) with the DMX ³ .
0 288 18 0 288 19 0 288 98 0 288 99	Insulated shield	PARTIALLY	Divider supports are supplied fixed on the DMX ³ . These dividers are supplied with the DMX ³ .
0 289 09 0 289 10 0 289 11 0 289 12 0 289 15 0 289 16	Conversion kits (fixed version to draw-out version)	Moving parts: YES Fixed parts: NO	The DMX ³ is completely transformed into a draw-out version (moving part), but is supplied without the base. Accessories required to fit the fixed base are supplied with the DMX ³ .
0 289 18 0 289 20 to 0 289 25	Interlocking cables	NO	After ordering, the accessories come (unmounted) with the DMX ³ .



All DMX³ devices are delivered in wooden crates



The devices are mounted on a pallet

COMMISSIONING

Before proceeding with the first mechanical tests and powering up the DMX³ for the first time, for the safety of people and equipment you must first ensure that the rules for best practice and the recommended installation conditions are met, and that only trained and authorised persons work on the equipment.

DE-ENERGISED CHECKS

- Check the physical integrity of the device. If a part is missing, or it is damaged, replace it. For a draw-out device, check that you can draw out and plug in the product without difficulty, paying particular attention to the plug-in terminals of the electrical auxiliaries.
- Check the compatibility of the electrical accessories (coils, motors and protection unit) installed in relation to the overall scheme and the instructions for the installed products.

- For the air circuit breakers, check the operation of the protection unit. It is necessary to install the batteries in their slot, and perform the various settings on the protection unit. Check the battery charge status, set the reset button to the "MAN" position, power off, close the circuit breaker and press the test button of the protection unit for two seconds for the MP4, or six seconds for the MP6. The circuit breaker must open, check that all the LEDs light up, and that the reset button has actuated (stands proud of its slot). Remember to acknowledge the fault by pressing the reset button. With MP4 units, the test should be limited to five tests to ensure sufficient battery charge, otherwise use the dedicated power supply Cat. No. 0 288 06. For testing MP6 units, this power supply is essential.

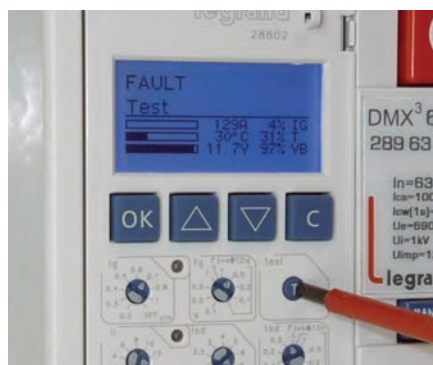

- Perform two DMX³ open/close cycles, always with the power off, checking specifically the indications on the front of the DMX³.

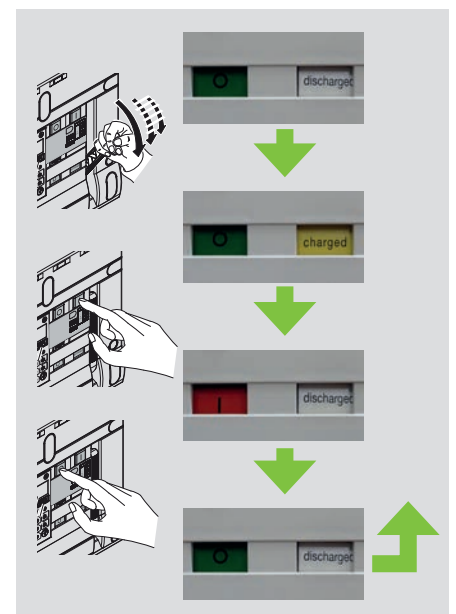

- When using DMX³ as supply inverters, it is necessary to ensure that the truth table is respected.
- If there are locking accessories installed on the DMX³, make sure that the function of each is ensured.

ENERGISED CHECKS

- Dielectric test

Prior to testing at nominal voltages, it is necessary to perform the dielectric test. This standard test must be performed in accordance with certain conditions in order to not damage the electronics of the DMX³. On the front panel of the equipped circuit breaker, it is mandatory to switch the "Dielectric test" selector switch from the "normal use" position to the "trip" position, before performing the dielectric test. After the dielectric test, reset the cursor to the "normal use" position, otherwise it would be impossible to close the circuit breaker. It is advisable to seal the selector switch during the dielectric tests to prevent accidental tampering. In the absence of this selector switch, on some product configurations, the dielectric test can normally be performed with the power poles closed.

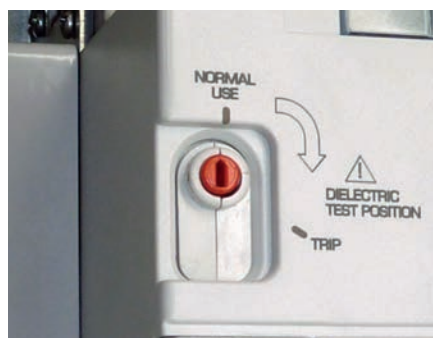

SELECTOR SWITCH IN "NORMAL USE" POSITION:

The selector switch is pressed and the voltage taps of the protection unit are connected to the power poles. The DMX³ can be used normally.

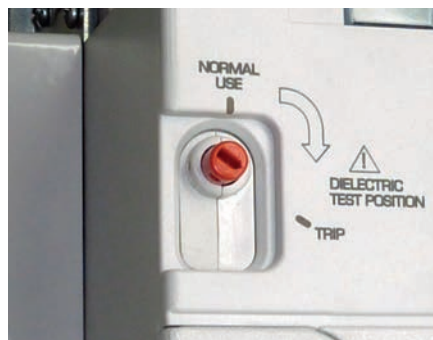

SELECTOR SWITCH IN "TRIP" POSITION:

The selector switch is in the extended position, the voltage taps are disconnected from the power supply. It is impossible to close the DMX³, and if it was in the closed position, its poles are still open. Dielectric tests can be performed.

- Check, at nominal voltage, that the various electrical auxiliaries (motor and coils) are functioning correctly.

All product instructions must be available at the time of delivery of the device. You can find them in the Legrand e-catalogue.

MAINTENANCE

! Before working on a DMX³ or DMX³-I device, it must be de-energised at the upstream and downstream terminals. Only authorised personnel may work on the equipment by ensuring it is inoperative and the area is cordoned off if necessary.

For a fixed device, it is preferable to cut the power supply upstream and downstream, or otherwise to ensure that the live parts are inaccessible to the maintenance engineer. For a draw-out device, it must be locked in the "drawn out" position.

PREVENTIVE MAINTENANCE

DMX³ devices are supplied for a number of cycles. This service life can be increased if the DMX³ is subject to regular preventive maintenance.

It is important to perform maintenance in order to:

- Ensure electrical and mechanical performance of the product
- Identify worn or damaged parts or accessories
- Prevent breakdowns

i For more information on DMX³ maintenance, contact Legrand Customer Service.

i For more details regarding the frequency and content of maintenance procedures, refer to the maintenance guide Y2762 available in the e-catalogue.

Periodical maintenance and inspections are recommended on the following parts:

- Mechanism
- Mechanical interlock
- Locks
- Spring
- Arc chambers and spark gaps
- Main power contacts
- Draw-out base
- The connector block of the electrical auxiliaries
- Electric auxiliaries
- Mechanical accessories
- Electrical accessories
- Protection unit

For any requests made to the Pro Relations department, you will be asked for the serial numbers or dates of manufacture of the DMX³ and its components.

The date of manufacture is coded as "Year W Week" (for example 13W10 is the 10th week of 2013).



On the right side of the DMX³, the end of the serial number is engraved on the metal structure and is shown in full, with the date of manufacture on a sticker.



For all accessories, the date of manufacture is marked on a small sticker, as well as on the packaging label.

RETROFITTING

Retrofitting accessories allow the replacement of older DMX devices with the latest generation DMX³ products. This avoids the need for major maintenance operations upstream and downstream of the busbars, and on the mounting plate. Only the remote control cables must be modified to be consistent with the DMX³ terminal block.

All DMX versions can be replaced by a DMX³ with the same characteristics, namely: air circuit breaker or trip-free switch, fixed or draw-out version, 3 or 4-pole.

Retrofitting kits must be ordered along with the DMX³ in order to be configured at the factory. The connection plates require special machining to fit perfectly with existing connections.



These retrofitting kits can be used to replace a single device and for replacing a device in a supply inverter system with two DMXs. In the case of a DMX installed in a triple inverter, contact Legrand Customer Service.



For more information on retrofitting, contact Legrand Customer Service.

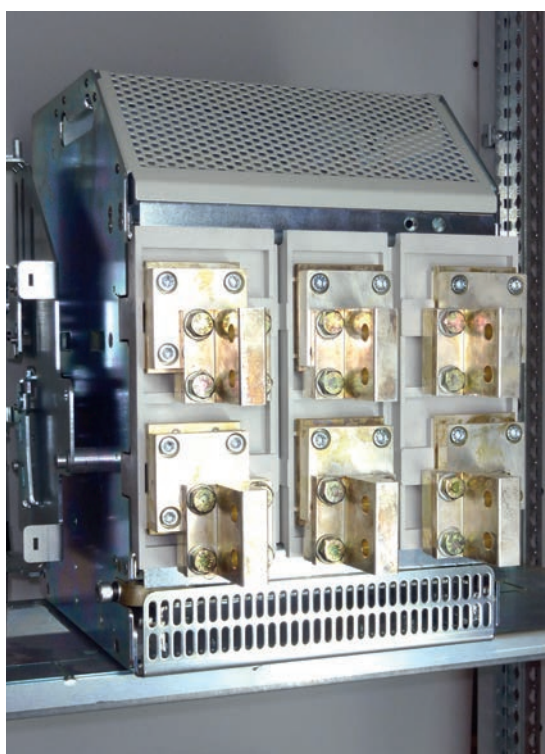

Draw-out DMX³ Size 2500, 3-pole, equipped with retrofitting kit, with reuse of DMX orientable connectors

TO REPLACE AN DMX TO AN DMX³, YOU NEED:

New DMX³ (or DMX³ -i)



...Retrofit kit

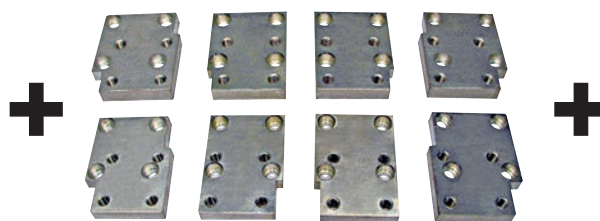

NB: the switch and retrofit kit are factory assembled

Kit for integration into XL³ enclosures (plate and faceplate)



0 290 90

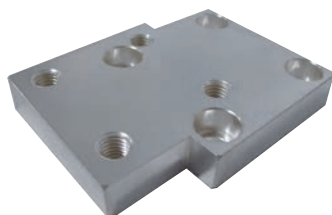

0 290 91



0 209 33



Cat.Nos	Retrofit kits
	For DMX³ - Frame 2500, fixed version Rated current from 800 A to 2500 A
0 290 90	For 3P DMX ³
0 290 92	For 4P DMX ³
	For DMX³ - Frame 2500, draw-out version Rated current from 800 A to 2500 A
0 290 91	For 3P DMX ³
0 290 93	For 4P DMX ³
	For DMX³ - Frame 4000, fixed version Rated current from 800 A to 4000 A
0 290 94	For 3P DMX ³
0 290 96	For 4P DMX ³
	For DMX³ - Frame 4000, draw-out version Rated current from 800 A to 4000 A
0 290 95	For 3P DMX ³
0 290 97	For 4P DMX ³

Cat.Nos	Additional kit for integration into XL ³ 4000 enclosures
	For DMX³ fixed version
0 209 33	For XL ³ 4000 usable width 600 mm
0 209 83	For XL ³ 4000 usable width 850 mm
	For DMX³ draw-out version
0 209 37	For XL ³ 4000 usable width 600 mm
0 209 85	For XL ³ 4000 usable width 850 mm

SPARE PARTS







Parts for DMX³ are to be used and installed by authorised persons. All parts are supplied with instructions for the disassembly and reassembly of the part in question.

PARTS FOR DMX³

CAT. NO.	DESCRIPTION	CONTENTS	INFORMATION	DEVICE		
				SIZE	NUMBER OF POLES	
0 290 21	Battery kit for the DMX ³	<ul style="list-style-type: none"> - Extractor x 1 - Cover x 1 - Screws x 2 - Batteries x 4 - Instructions 		Kit for 1 protection unit	All	3P and 4P
0 288 22	Door frame	<ul style="list-style-type: none"> - Seal x 1 - Frame x 1 - Screws x 10 - Instructions 		Kit for 1 fixed or draw-out air circuit breaker or trip-free switch	All	3P and 4P
0 290 00	Arc chamber	<ul style="list-style-type: none"> - Arc chamber: sizes 2500/4000: x 1 size 6300: x 2 - Screws: sizes 2500/4000: x 2 size 6300: x 4 - Instructions 		Kit required for 1 pole	2500	3P and 4P
0 290 46					4000 and 6300	3P and 4P
0 290 47	Current sensor (CT + Rogowski)	<ul style="list-style-type: none"> - Current sensor: sizes 2500/4000: x 1 size 6300: x 2 - Screws: size 2500: x 2 size 4000: x 4 size 6300: x 8 - Instructions 		Kit required for 1 pole	2500	3P and 4P
0 290 03					4000	3P and 4P
0 290 60					6300	3P and 4P
4 210 95	Sealing kit			x 4	All	3P and 4P

CAT. NO.	DESCRIPTION	CONTENTS	INFORMATION	DEVICE		
				SIZE	NUMBER OF POLES	
0 290 14	Front panel for air circuit breaker	<ul style="list-style-type: none"> - Front panel - Covers for fixed and draw-out versions - Screws x 4 - Caps for screws x 2 - Instructions 		Kit required for 1 fixed or draw-out air circuit breaker	All	3P and 4P
0 290 15	Front panel for trip-free switch	<ul style="list-style-type: none"> - Front panel - Covers for fixed and draw-out versions - Screws x 4 - Caps for screws x 2 - Instructions 		Kit required for 1 fixed or draw-out trip-free switch	All	3P and 4P
0 290 68	Caps for front panel fixing screws	<ul style="list-style-type: none"> - Caps for screws x 10 - Instructions 		Kit required for 5 DMX ³	All	3P and 4P
0 290 16	Secondary front panel	<ul style="list-style-type: none"> - Covers for secondary front panels: size 2500 - 4P: x1 size 4000: x 2 size 6300 - 3P: x 4 size 6300 - 4P: x 6 - Screws: size 2500 - 4P: x 2 size 4000 - 3P: x 4 size 4000 - 4P: x 6 size 6300 - 3P: x 10 size 6300 - 4P: x 14 - Instructions 		Kit required for 1 DMX ³	2500	4P
0 290 17					4000	3P
0 290 55					4000	4P
0 290 61					6300	3P
0 290 62					6300	4P
0 290 12	Support for auxiliary terminal block	<ul style="list-style-type: none"> - Support for auxiliary terminal block - Fixing kit for fixed and draw-out versions - Instructions 		Kit required for 1 fixed or draw-out DMX ³	All	3P and 4P
0 290 52	Fixed terminal block for connection	<ul style="list-style-type: none"> - Fixed terminal block for connection x 10 - Instructions 		Kit required for 10 electrical auxiliaries	All	3P and 4P
0 290 50	Dummy fixed terminal block	<ul style="list-style-type: none"> - Dummy fixed terminal block x 10 Instructions 		Kit required for 10 empty slots (not used by fixed terminal block for electric auxiliaries - aesthetic use)	All	3P and 4P

SPARE PARTS

CAT. NO.	DESCRIPTION	CONTENTS	INFORMATION	DEVICE		
				SIZE	NUMBER OF POLES	
0 290 54	Terminal block for protection unit	<ul style="list-style-type: none"> - Cover - Support - Electronic card (standard version) - Screws - Transparent protection x 2 - Instructions 		Kit required for 1 air circuit breaker	All	3P and 4P
0 290 22	Protection cover for the protection unit	<ul style="list-style-type: none"> - Cover for MP4 x 1 - Cover for MP6 x 1 - Mini-USB blanking plate - Instructions 		Kit required for 1 protection unit (MP4 or MP6)	All	3P and 4P
0 290 09	Auxiliary contact for protection unit	<ul style="list-style-type: none"> - Auxiliary contact for protection unit - Insulation plate - Benzing ring - Instructions 		Kit required for 1 air circuit breaker	All	3P and 4P
0 290 20	Dielectric selector switch	<ul style="list-style-type: none"> - Dielectric selector switch - Screws - Trip lever - Lever shaft - Lever spring - Benzing ring - Instructions 		Kit required for 1 air circuit breaker	All	3P and 4P
0 290 08	Spring charging lever	<ul style="list-style-type: none"> - Lever for air circuit breaker (black) - Lever for trip-free switch (grey) - Spring charging mechanism - Benzing ring - Seiger ring - Springs - Instructions 		Kit required for 1 device (air circuit breaker or trip-free switch)	All	3P and 4P
0 290 31	Earth connection kit for fixed device	<ul style="list-style-type: none"> - Earth connection - Fixing screws - Connection kit - Instructions 		Kit required for 1 fixed device manufactured before week 32 of 2012.	All	3P and 4P
0 290 32	Earth connection kit for draw-out device	<ul style="list-style-type: none"> - Earth connection - Fixing screws - Connection blade - Connection clamp - Instructions - Screws 		Kit required for 1 draw-out device	All	3P and 4P

PARTS FOR DMX³ ACCESSORIES

CAT. NO.	DESCRIPTION	CONTENTS	INFORMATION	DEVICE			
				SIZE	NUMBER OF POLES		
0 290 27	Extraction crank	- Crank x 1 - Instructions		Kit required for 1 draw-out device	All 3P and 4P		
0 290 57	Extraction crank kit	- Crank - Handle case - Screws - Support - Instructions		Kit required for 1 draw-out device	All 3P and 4P		
0 290 56	Removable drawer	- Removable drawer - Instructions		Kit required for 1 draw-out device	2500	3P	
0 290 24						4P	
0 290 25						3P	
0 290 26						4P	
0 290 63						3P	
0 290 64						4P	
0 290 29	Connection clamp	- Connection clamp x 1 - Screws and washers - Instructions		Kit required for 1 pole (the kit for size 3 contains only one clamp)	2500	All	
0 290 30						4000	All
0 290 67						6300	All
0 290 33	Safety shutter	- Mobile shutter - Fixed shutter - Springs - Screws		Kit required for 1 draw-out device	2500	3P	
0 290 34						4P	
0 290 35						3P	
0 290 36						4P	
0 290 65						3P	
0 290 66						4P	
0 290 69	Contact and connector replacement kit	- Repair kit for electrical auxiliaries - Instructions		2 auxiliary contacts with connector 1 motor connector 3 replacement connectors	All 3P and 4P		

TOOLS AND SUPPLIES FOR DMX³ MAINTENANCE

CAT. NO.	DESCRIPTION	CONTENTS	INFORMATION	DEVICE	
				SIZE	NUMBER OF POLES
0 290 40	Tool for inspecting connection clamps	- Left tool - Right tool - Instructions		Tool required to open safety shutters manually	All 3P and 4P
Contact Legrand	Grease	- Mechanical grease		Mechanical greasing kit (0,5Kg). Components enough for 10 devices size 2500/4000 or 7 size 6300.	All 3P and 4P

To know more, check [legrand.com](http://www.legrand.com)



All technical data of the products inside this workshop specifications book are available on: www.legrand.com/ecatalogue/

Click on **>DOWNLOAD DOCUMENTS**

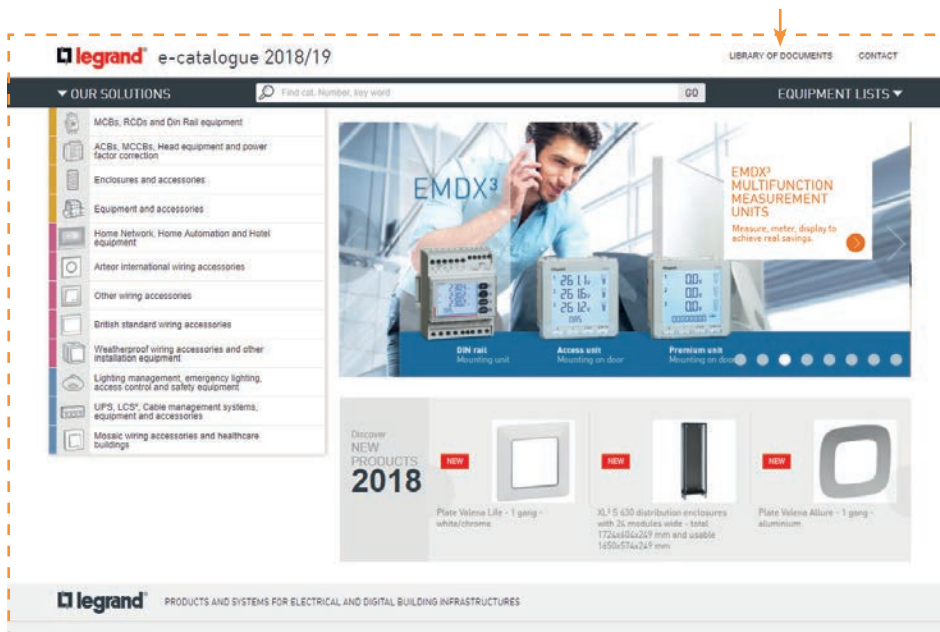

>Library of documents

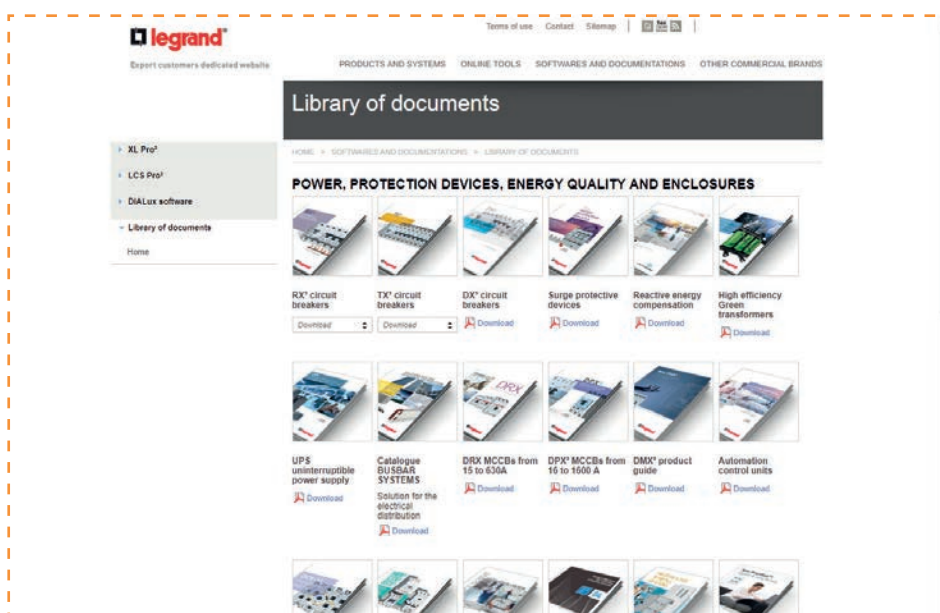

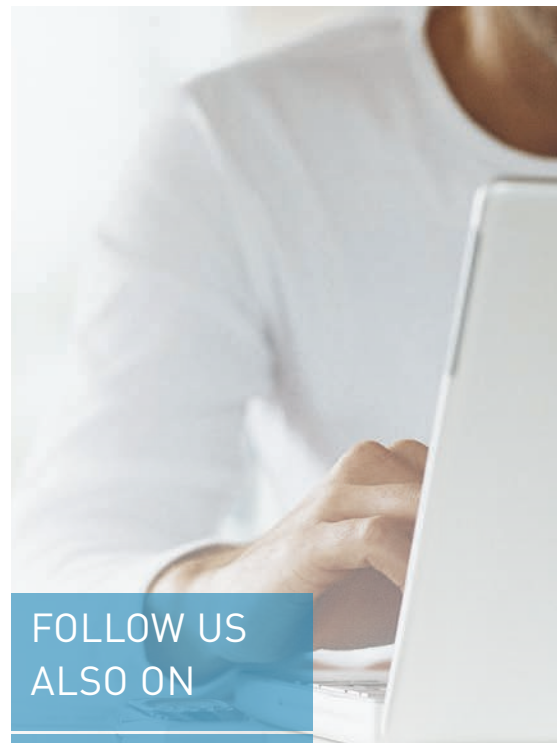

FOLLOW US
ALSO ON

- @ legrand.com
-  youtube.com/user/legrand
-  facebook.com/Legrand
-  twitter.com/Legrand
-  pinterest.com/legrandgroup
-  instagram.com/legrandnews



Head office
and International Department
87045 Limoges Cedex - France
Tel: + 33 (0) 5 55 06 87 87
Fax: + 33 (0) 5 55 06 74 55