

GREEN.T.HE high efficiency transformers

CONFORMING TO **IEC 60076-11**
AND **EU REGULATION 548/2014**



Global strength built on local knowledge

Legrand is the global specialist in electrical and digital building infrastructures. Innovation is the driving force behind its development.

With an increasing investment in research and development (circa 5% of sales) and more than 4,000 active patents, the Legrand Group is focused on maintaining a high rate of new product launches that present innovative solutions to the market.

CORPORATE SOCIAL RESPONSIBILITY

Legrand's CSR roadmap is a natural extension to the governance and sustainable development approach in which the company has been engaged for many years. The CSR roadmap firmly asserts Legrand's ongoing commitment to sustainable development.

Respect human rights and communities
Ensure health, safety and well-being
Develop skills
Promote equal opportunity and diversity



Provide sustainable solutions
Ensure sustainable procurement
Act ethically

Mitigate climate change
Innovate for the circular economy
Prevent pollution



BUILDING SERVICES



INFRASTRUCTURE



DATA CENTRES



HEAVY INDUSTRIES



Product Environmental Profile
Green Transformers High Efficiency

MEETING THE ECODESIGN DIRECTIVE

From July 2021 (tier 2), regulation 548/2014 (updated by regulation 2019/1783) requires manufacturers to produce **transformers with no-load loss reduced by 10%** compared with the previous requirement.

The Legrand Green T.HE transformers fully comply with the new eco-compatible design rules and guarantee a significant reduction in energy consumption, thus promoting significant economic savings and the reduction of CO₂ emissions into the atmosphere.



PRODUCT SELECTION

Selection chart 12 kV class and technical dimensions	4
Installation accessories	6
Enclosures	7

TECHNICAL SPECIFICATIONS

Installing a Zucchini cast resin transformer	8
Medium and low voltage winding	9
Protection against temperature rise	11
Protection against overloads	12
Environmental and climatic features / fire resistance	14
Main vector groups of transformers / special extended LV bar arrangements	15
Compatibility with Zucchini busbar	16

CONTENTS

ADVANTAGES OF THE Green T.HE TRANSFORMERS



Low partial discharges,
HIGH quality



Partial discharges are microscopic phenomena occurring inside insulating resin cavities and are a factor in the speeding up of the ageing process of a transformer. Therefore, it is important that the values of such currents are limited.

According to the product standard regarding the design of resin transformers (IEC 60076-11), all windings with a voltage of ≥ 3.6 kV are subject to the measure of partial discharges and the value measured **should not exceed 10 pC (picocoulomb)**.

When the Green T.HE transformers were subjected to the measurement of partial discharges, the values detected were **always** below **5 pC**, significantly better than required by the standard.

A low value of partial discharges represents the index of some positive factors, such as:

- proper and solid design criteria
- quality raw materials
- precision during conductor foil winding phases
- competence during the epoxy resin pouring around the high-voltage winding
- accuracy in final assembling of the complete assembly

It is clearly evident that a **lower** level of partial discharge leads to a **higher** resistance to work stresses and consequently to a higher life expectancy of the transformer under examination.

TYPE OF PARTIAL DISCHARGE

Depending on the type, discharges can be divided into:

- **Corona effect** - discharge mechanism occurring in correspondence of sharp ends in dielectric gas
- **Superficial discharges**
- **Internal discharges** - representing the main cause of life-cycle decrease of the insulating material
- **Treeing** - branched discharge channel : it is the pre-discharge channel due to the insulation deterioration leading to destructive discharge



PRODUCT News

With the new Green T.HE series (tier 2), Legrand offers its customers a very high quality product, with excellent performance and reduced losses, in full compliance with regulation 548/2014 and subsequent updates (EU regulation 2019/1783).

Thanks to the use of innovative materials and the measures taken during their design, the new transformers are characterised by the following distinctive features:

- **HV** (high voltage) and **LV** (low voltage) **terminals** have been modified and built to facilitate the connection of the product on both windings



Updated LV terminals



Updated HV terminals

- The HV windings are all made in **BIL LIST 2**, thanks to the **reinforced insulation** in the critical points of the unit
- They guarantee very high performance and reduced losses compared to previous models, while maintaining equivalent weights and dimensions. All this is possible thanks to the completely new **magnetic core** with newly developed and high-performance materials

REINFORCED INSULATION

NEW MATERIALS FOR THE
MAGNETIC CORE

HIGHER PERFORMANCE
WITH LOW WEIGHTS AND
DIMENSIONS

New magnetic core

The new grain-oriented magnetic sheet has an even sharper crystallographic consistency and makes an important contribution to the realisation of even more efficient power and distribution transformers. The advantages of using this material are:

- lower core weights
- more compact dimensions
- greater energy efficiency through minimal no-load losses
- reduced noise development through optimised magnetic domain structure
- improved insulation properties

This means that when comparing two transformers of the same size, the one with the core built with the new sheet will have significantly lower no-load loss values and therefore better performance.

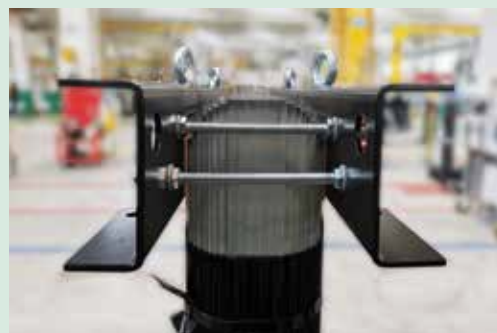

Green T.HE MV/LV cast resin transformers

12 kV insulation class

Technical information p. 8-16

CLASSIFICATION

The classification of a cast resin transformer depends on the value of the no-load loss (P_o), as well as the load loss (P_k).
More precisely, P_o losses are independent from the loads and remain constant for the whole time the transformer is connected to the electrical grid. On the other hand, P_k losses only occur when the transformer is feeding a load and they are proportional to the square of the load.

NO-LOAD LOSS (P_o)	LOAD LOSS (P_k)

ECODESIGN REQUIREMENTS - TIER 2 (from 1st July 2021)

Rated power [kVA]	Maximum no-load loss P_o [W]	Maximum load loss P_k [W]
≤ 50	$A_o - 10\%$ (180)	A_k (1 500)
100	$A_o - 10\%$ (252)	A_k (1 800)
160	$A_o - 10\%$ (360)	A_k (2 600)
250	$A_o - 10\%$ (468)	A_k (3 400)
400	$A_o - 10\%$ (675)	A_k (4 500)
630	$A_o - 10\%$ (990)	A_k (7 100)
800	$A_o - 10\%$ (1 170)	A_k (8 000)
1 000	$A_o - 10\%$ (1 395)	A_k (9 000)
1 250	$A_o - 10\%$ (1 620)	A_k (11 000)
1 600	$A_o - 10\%$ (1 980)	A_k (13 000)
2 000	$A_o - 10\%$ (2 340)	A_k (16 000)
2 500	$A_o - 10\%$ (2 790)	A_k (19 000)
3 150	$A_o - 10\%$ (3 420)	A_k (22 000)

Requirements applicable (losses values) to medium power three phase transformers with rated power ≤ 3 150 kVA dry type, and one winding U_m ≤ 24 kV

Insulation Class 12 kV

Compliance with standard : IEC 60076-11 / EU regulation 548/2014 (TIER 2)

Frequency (Hz) : 50

Adjustment, MV side : ± 2 x 2-5%

Vectorial group : Dyn11

Thermal class of the insulating system : 155 °C (F) / 155 °C (F)

Temperature rise : 100/100 K

Class of use : E3-C2-F1³

Tolerances : P_o and P_k have zero tolerances in line with the EU regulation 548/2014

BIL : 75 kV

S_R [kVA]	Series	U_k [%]	Primary voltage [kV]	Secondary voltage [V] Insulation class 1-1 kV	P_o [W]	P_k [W] at 120°C	I_o [%]	LwA-Acoustic power [dB (A)]	Length (A) ² [mm]	Width (B) ² [mm]	Height (C) ² [mm]	lc - wheel centre (E) ² [mm]	R - wheel diameter (D) ² [mm]	Weight [kg]	Box type
100	A _o -10%A _k	6	11	417 ¹	252	1 800	1	51	1 150	750	1 290	520	125	700	H1
160	A _o -10%A _k	6	11	417 ¹	360	2 600	1	54	1 200	750	1 310	520	125	820	H1
250	A _o -10%A _k	6	11	417 ¹	468	3 400	0.9	57	1 300	780	1 370	520	125	1 150	H1
315	A _o -10%A _k	6	11	417 ¹	557	3 875	0.8	58	1 350	850	1 430	670	125	1 250	H2
400	A _o -10%A _k	6	11	417 ¹	675	4 500	0.8	60	1 350	850	1 490	670	125	1 380	H2
500	A _o -10%A _k	6	11	417 ¹	811	5 630	0.7	60	1 450	850	1 540	670	125	1 600	H2
630	A _o -10%A _k	6	11	417 ¹	990	7 100	0.7	62	1 450	850	1 600	670	125	1 800	H2
800	A _o -10%A _k	6	11	417 ¹	1 170	8 000	0.6	64	1 550	1 000	1 440	820	160	2 200	H3
1 000	A _o -10%A _k	6	11	417 ¹	1 395	9 000	0.6	65	1 600	1 000	1 960	820	160	2 800	H3
1 250	A _o -10%A _k	6	11	417 ¹	1 620	11 000	0.6	67	1 700	1 000	1 980	820	160	3 250	H3
1 500	A _o -10%A _k	6	11	417 ¹	1 877	12 428	0.5	68	1 750	1 000	2 130	820	160	3 900	H4
1 600	A _o -10%A _k	6	11	417 ¹	1 980	13 000	0.5	68	1 750	1 000	2 150	820	160	3 900	H4
2 000	A _o -10%A _k	6	11	417 ¹	2 340	16 000	0.4	70	1 850	1 000	2 240	820	200	4 650	H4
2 500	A _o -10%A _k	6	11	417 ¹	2 790	19 000	0.4	71	2 000	1 500	2 310	1 070	200	5 550	H5
3 150	A _o -10%A _k	6	11	417 ¹	3 420	22 000	0.35	71	2 200	1 500	2 400	1 070	200	7 100	H5

1 : Also available in 400, 415, 420 and 433 V

2 : See illustration on p. 5 for length (A), width (B) and height (C) dimensions, and wheel diameter (D) and wheel centre dimension (E)

3 : Class of E4-C2-F1 available on request, please contact us on +44 (0) 370 608 9020

Other insulation classes, such as 17-5, 24 and 36 kV, available on request along with other primary voltages, such as 6-6 kV, please contact us on +44 (0) 370 608 9020

Green T.HE MV/LV cast resin transformers

technical information

■ Technical dimensions

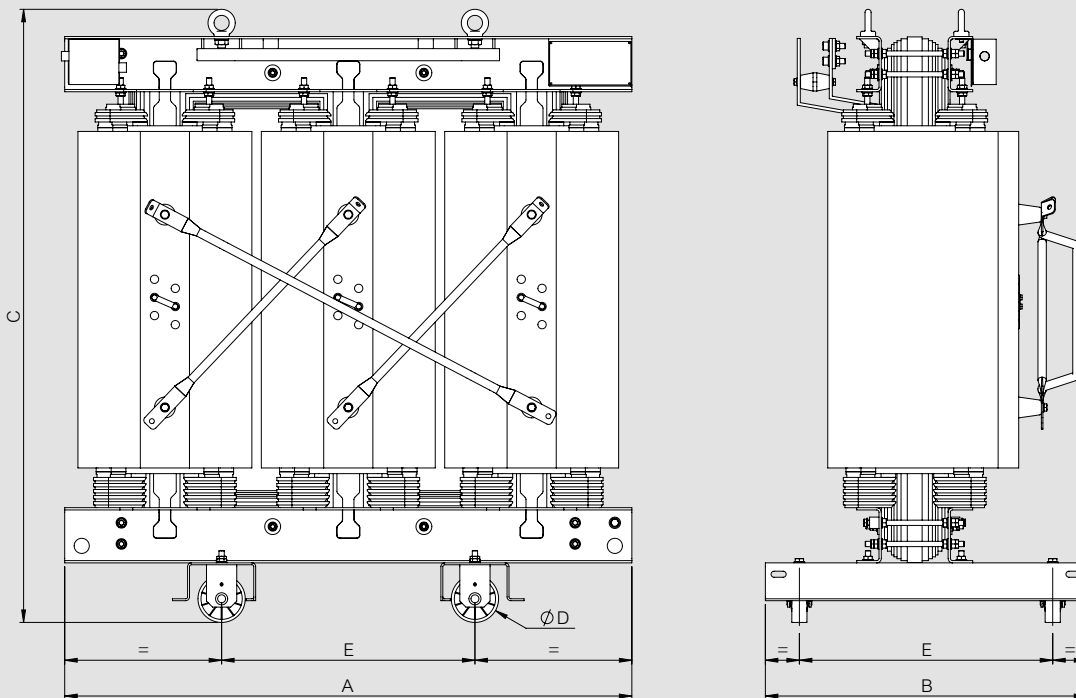

Values are for reference only
 Construction drawings must be used for design
 Data provided may be modified without warning for reasons of technical production
 or product improvement
 For dimension see table of technical information on p. 4

■ Dimensions and holes of the LV connection terminals

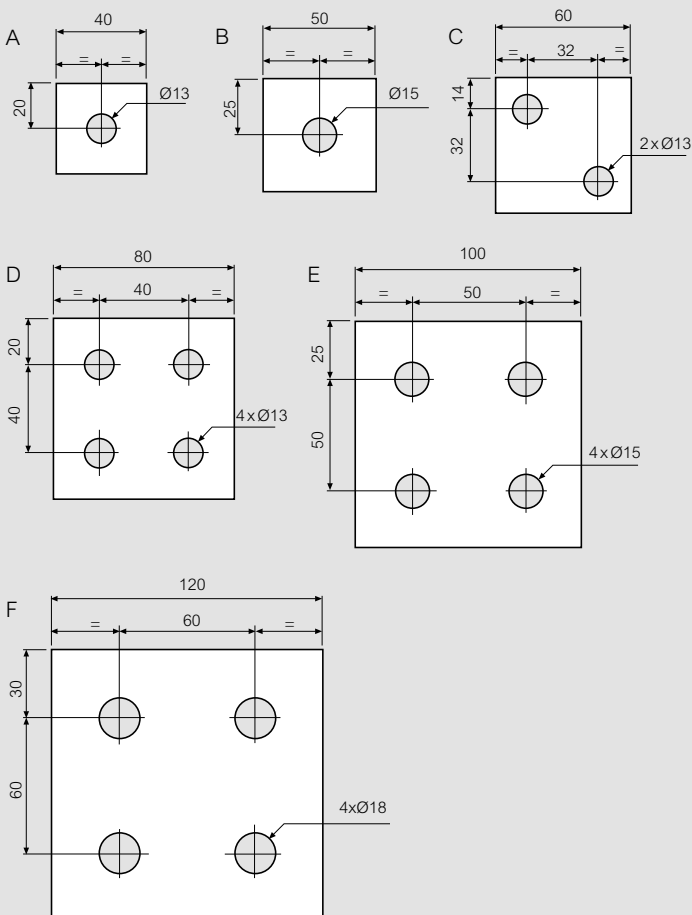

Updated HV terminals

Standard hole details

The LV connection terminals are made of aluminium. Appropriate CUPAL bimetal plates are also available for copper connections

Drawing	Range [kVA]	Thickness [mm]
A	100	4
	160	
B	250	5
	315	
C	400	6
	500	
	630	
D	630	8
E	800	8
F	1000	8
	1250	
	1600	
	2000	
	2500	
	3150	24

Green T.HE MV/LV cast resin transformers

installation accessories



IP 65 junction box



Pt100 temperature measurement sensors



Ventilation fans

Selection charts **p. 4**
 Technical information and dimensions **p. 8-16**

Pack	Cat. Nos.	Temperature measurement sensors				
		Temperature measurement sensors are supplied mounted on to the transformer and wired to aluminium IP 65 junction box				
		Type	Range (kVA)	No.	Δt (°C)	Installation
3	200073	Pt100	≤2000	3	–	on the LV (3) windings
3	200074	Pt100	>2500	3	–	on the LV (3) windings
4	200137	Pt100	≤2000	3 + 1	–	on the LV (3) windings + on the core (1)
4	200138	Pt100	>2500	3 + 1	–	on the LV (3) windings + on the core (1)
6	CB00120	PTC	–	3 x 2	130-140	on the LV (3 pairs) windings for alarm and release
6	CB02400	PTC	–	3 x 2	110-120	on the LV (3 pairs) windings for alarm and release
9	CB0272	PTC	–	3 x 3	130-140 -90	on the LV (3 pairs) windings for fan control, alarm and release

Pack	Cat. Nos.	Temperature control devices	
		Control units are supplied unassembled	
		Type	Description
1	220002	T154	Temperature control for 3 or 4 Pt100 probes
1	220023	MT200L	Temperature control for 3 or 4 Pt100 probes
1	220197	NT935AD	Temperature control for 3 or 4 Pt100 probes with analogue or digital output
1	220211	MT200LITES	Temperature control for 3 or 4 Pt100 probes with digital output
1	220219	NT935ETH	Temperature control for 3 or 4 Pt100 probes with ethernet output
1	220218	MT200LITEE	Temperature control for 3 or 4 Pt100 probes with ethernet output
1	220212	NT538AD	Temperature control for up to 8 Pt100 probes with analogue or digital output
1	220004	T119	Temperature control for 6 PTC probes
1	220010	T119 DIN	Temperature control for 6 PTC probes, preset for DIN rail mounting
1	220024	MT300	Temperature control for 6 PTC probes, preset for DIN rail mounting
1	220035	VRT200	Fan control
1	220174	AT100	Fan control

Pack	Cat. Nos.	Ventilation fans	
		According to IEC 60076-1, a transformer is called AN even if it is equipped with discontinuous ventilation If a transformer with AF continuous duty power is required, please contact us on +44 (0) 0370 608 9020 Ventilation fans allow a temporary increase of the rated power (under normal service conditions)	
		Range (kV)	ΔPower (%)
1	CB02444	100 - 250	+40
1	CB02454	315 - 630	+40
1	CB02464	800 - 1000	+40
1	CB01414	1250 - 2000	+40
1	CB01412	2500 - 3150	+40

Pack	Cat. Nos.	Surge arrester kit	
		Supplied mounted on the transformer	
		Voltage HV ¹ (kV)	Ur ² (kV)
1	130075D	6	9
1	130054D	10-11	12
1	130055D	15	18
1	130056D	20	24

Pack	Cat. Nos.	Rubber supports (anti-vibration)	
		4 anti-vibration pads for mounting under transformer casters	
		Range (kVA)	
1	170019	≤ 2000	
1	170020	≥ 2500	

Pack	Cat. Nos.	Cupal plates	
		Cupal is a bimetal sheet made up of one copper sheet and one aluminium sheet welded together through a special mechanical procedure Cat. Nos. refer to a single CUPAL sheet Example : for a transformer with a power of 1250 kVA, the correct CUPAL plate is Cat. No. 030012 1 CUPAL has 2 plates (1 aluminium and 1 copper) therefore for quantity calculation - 2 plates x 4 LV terminals = 8 CUPAL plates	
		Range (kVA)	Size of Cupal plate (mm)
1	030014	≤ 160	40 x 40
1	030008	250	50 x 50
1	030009	≥ 315 and ≤ 500	60 x 60
1	030010	630	80 x 80
1	030011	800	100 x 100
1	030012	≥ 1000	120 x 120

1 : Other HV values are available on request, for more information contact us + 44 (0) 0370 608 9020
 2 : Ur - rated voltage of the surge arrester

Green T.HE MV/LV cast resin transformers

installation accessories (continued) and enclosures



IP 31 enclosure

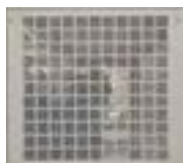

Enclosure ventilation grid IP 31



Enclosure ventilation grid IP 23

Selection charts **p. 4**
 Technical information and dimensions **p. 8-16**

Pack	Cat. Nos.	Enclosures						
		Insulation Class 12 / 17.5 / 24 kV Degree of protection : IP 23 / IP 31 Colour RAL 7035 Boxes can be supplied or assembled on the transformer						
		Box type	IP degree	Assembled (M) / Self-assembly (S)	Dimensions (mm)			Weight (kg)
					Length (A)	Width (B)	Height (C)	
1	BXM23H1	H1	IP23	M	1800	1150	1800	170
1	BXM23H2	H2	IP23	M	1800	1200	2100	200
1	BXM23H3	H3	IP23	M	2100	1300	2450	250
1	BXM23H4	H4	IP23	M	2300	1350	2750	280
1	BXM23H5	H5	IP23	M	2600	1500	2750	330
1	BXS23H1	H1	IP23	S	1800	1150	1800	170
1	BXS23H2	H2	IP23	S	1800	1200	2100	200
1	BXS23H3	H3	IP23	S	2100	1300	2450	250
1	BXS23H4	H4	IP23	S	2300	1350	2750	280
1	BXS23H5	H5	IP23	S	2600	1500	2750	330
1	BXM31H1	H1	IP31	M	1800	1150	1800	150
1	BXM31H2	H2	IP31	M	1800	1200	2100	180
1	BXM31H3	H3	IP31	M	2100	1300	2450	230
1	BXM31H4	H4	IP31	M	2300	1350	2750	260
1	BXM31H5	H5	IP31	M	2600	1500	2750	300
1	BXS31H1	H1	IP31	S	1800	1150	1800	150
1	BXS32H2	H2	IP31	S	1800	1200	2100	180
1	BXS33H3	H3	IP31	S	2100	1300	2450	230
1	BXS34H4	H4	IP31	S	2300	1350	2750	260
1	BXS35H5	H5	IP31	S	2600	1500	2750	300

Green T.HE MV/LV cast resin transformers

technical dimensions

Technical dimensions

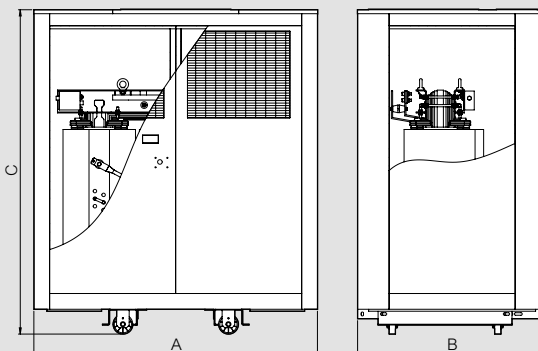

Freestanding enclosures

The Legrand Group offer meets the needs of any installation by also offering different types of enclosure
 The version illustrated below shows a freestanding enclosure which is suitable for Legrand Green T.HE Tier 2 transformers

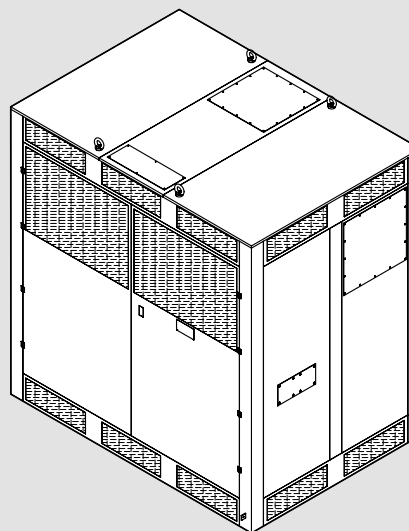

Other enclosures including freestanding options are available on request, please contact us on +44 (0) 370 608 9020

Green T.HE MV/LV cast resin transformers

constructional characteristics

■ Installing a Zucchini cast resin transformer

Zucchini cast resin transformers are distinguished by their high quality production. Using state-of-the-art constructional techniques and equipment, quality is assessed throughout the production process and via a rigorous checking process in the final phase, resulting in a high quality, reliable product.

Zucchini cast resin transformers can be installed quickly and easily.

With no additional construction or building activities necessary, safe installation is ensured by following a few simple steps :

- Standard execution – indoor installation, in dry / clean environments, protected from direct sunlight, with no possibility of water ingress
- Altitude no higher than 1000 m above sea level (for higher installations, contact us on +44 (0) 370 608 9020)
- Room temperature with transformer in operation (for higher values, contact us on +44 (0) 370 608 9020) :
 - T minimum – 25°C
 - T maximum + 40°C
- With a standard execution, transformers are designed in accordance with IEC Standard 60076-11 for the following room air temperatures :
 - 40°C at peak times
 - 30°C as a monthly average in the warmest month
 - 20°C as a yearly average
- To protect the transformers from external environment impacts and/or people from the risk of having direct contact, a set of standard enclosures is available with different degrees of protection : IP 31 / IP 23

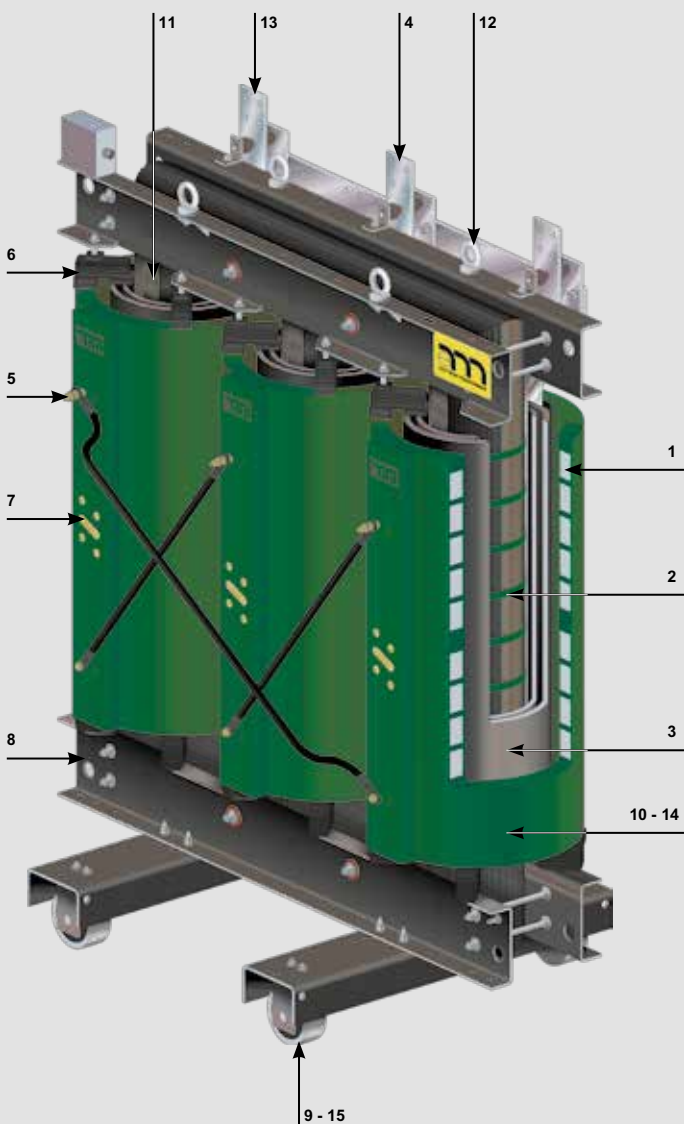

- 1 MV windings in aluminium strip coils, cast in resin under vacuum
- 2 Core in three columns in magnetic lamination with high-permeability oriented crystals, also available with low losses
- 3 LV windings in aluminium plate/sheet and vacuum-cast impregnated insulation material
- 4 LV connections upwards (standard) or downwards version (on request)
- 5 MV connections upwards (standard) or downwards version (on request)
- 6 Rubber inserts attenuate the transmission of vibrations between core and windings, and reduce operating noise generated by the transformer to a minimum, as well as absorbing the thermal expansion of the components
- 7 Off load links on the MV side to adapt the primary voltage to the mains, which can be set with transformer switched OFF
- 8 Structure, armatures and carriage, manufactured from strong painted sheet steel
- 9 Carriage with bi-directional castors
- 10 The epoxy resin insulation makes the transformer low maintenance
- 11 The operating temperature is checked by Pt100 sensor or PTC in the LV windings
- 12 Lifting eyebolts conform to the DIN-580 UNI-2947 standards with safety hooking at 4 points
- 13 Optional pre-equipment for connection of the LV connection to Zucchini busbar trunking system
- 14 Class F insulating material, at 155°C, allowing for a temperature rise of 100°K. (100°C)
- 15 The carriage allows safe movement and is pre-equipped for mounting IP reinforced boxes

Product image is for illustrative purposes only

Green T.HE MV/LV cast resin transformers

technical information

■ Medium voltage (MV) winding

The medium voltage winding, made by highly automated winding machines, is constructed with the continuous disk technique and made in aluminium strip, interleaved with double insulation

This type of working produces uniformity of the internal and external thickness of the resin and guarantees uniform resistance to the dielectric stresses to which the transformer will be subjected in the inspection phase or during its operation at the place of installation

The primary winding has off load links to adjust the primary voltage equal to the value $\pm 2 \times 2.5\%$, made with brass bushes protruding from the resin, and brass nuts and bolts with indelible numbering (not with adhesive labels)

The thermal class of the insulating materials used corresponds to class F, with the temperature rises allowed by standard IEC 60076-11



Modern electronically controlled winding machines



The pouring system under high vacuum

The technology used in making the MV windings in strips, rather than in wire, puts less stress on the insulation between the turns. In traditional windings, made with a circular-section conductor, each layer of the winding is made up of a number of turns side by side. In windings made with strip conductors, each layer is made up of just one turn. If the voltage of a single turn of a winding is denoted by u_s , in strip windings the voltage between turns belonging to two adjacent layers is always u_s , while in traditional windings this voltage assumes the maximum value of $(2n - 1) u_s$, as shown in the diagram below

Division of the voltage between the turns of the medium voltage winding

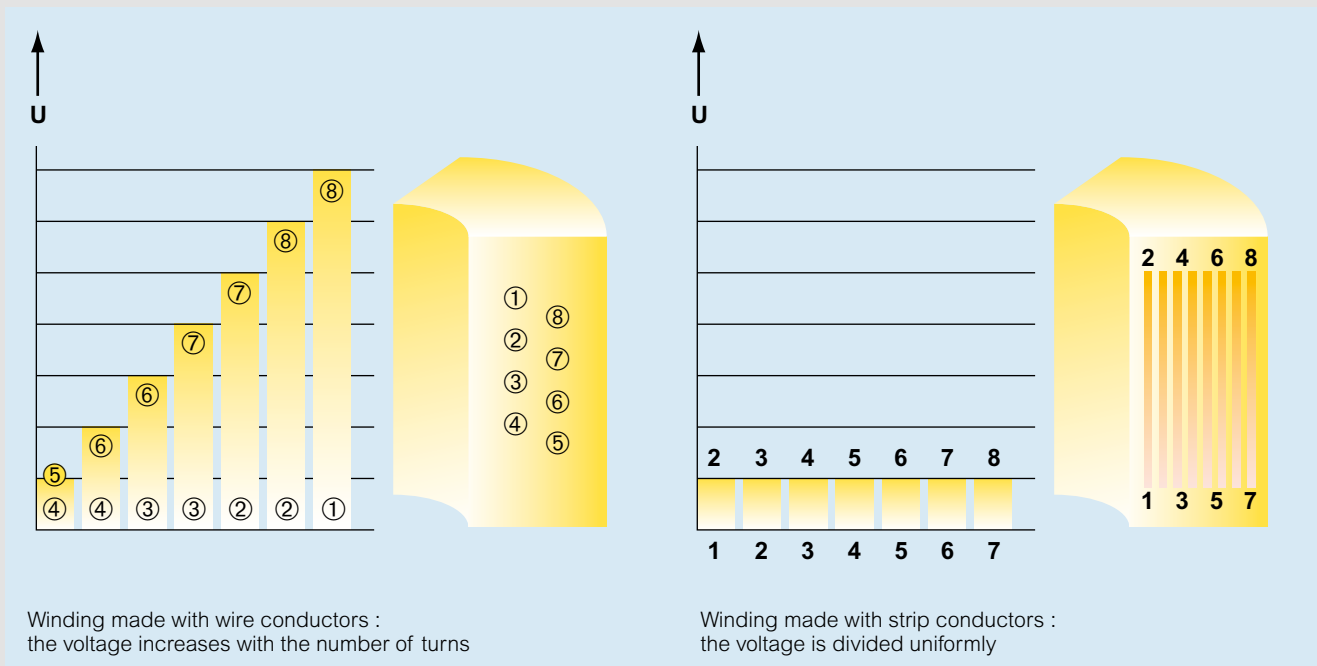

Transformers with strip windings thus have a greater capacity of resistance to impulse voltages and at industrial frequencies, as well as a lower probability of occurrence of localised partial discharges. Strip winding also has the advantage of drastically reducing the axial forces due to short-circuit currents

Green T.HE MV/LV cast resin transformers

technical information (continued)

■ Low voltage (LV) winding

The low voltage winding is made up of a single aluminium strip, of the same mechanical height as the MV electrical winding, with an interleaved sheet of insulating material which can be Class F or Class H. Making the winding in this way guarantees a compactness which forms a single cylinder that resists any axial and radial forces that may arise from a short-circuit

All the welds of the conductor strip with the output bars are made by butt welding in an inert atmosphere and under electronic control, so as to avoid any excess of material which could, by repeated stress, affect or damage the insulation interposed between output terminal and the following turn

This winding is then impregnated with epoxy resin, under vacuum, to confer the necessary compactness and homogeneity, as well as avoiding the absorption of humidity during the transformer's lifetime, wherever it may operate

This treatment means the system meets classification at level F1 according to standards IEC 60726 and IEC 60076-11



LV winding system



TIG welding in controlled atmosphere for LV connections

■ Protection against temperature rise

During its normal operation a transformer has no-load losses and load losses which fundamentally translate into dispersed thermal energy. This energy depends on the construction of the transformer itself, its power and the installation conditions. It should be remembered that the energy dispersed thermally is proportional to the transformer temperature minus the room temperature. At a given room temperature, the transformer temperature depends mainly on the load losses. As the load increases consequently the losses and the room temperature increase favouring a more rapid degradation of the insulations and thus a greater probability of failure of the dielectric. This situation could also occur when, with equal losses due to load, the room temperature and consequently the transformer temperature, increase. The IEC 60085 standard defines insulation classes which indicate the maximum temperatures that can be reached by the transformers in their normal operation and which must not be exceeded



Pt100 sensor to check the temperature

Insulation classes

Class	Transformers	Average temperature rise limits, at rated current
Class F (155°C)	resin	100° K

Temperature rises depend not only on the load and the overcurrents that may be detected by the protection devices, but also on environmental factors (inefficiency of the cooling system, fault on the forced ventilation and increase of the room temperature) which influence the dispersal of heat produced by the transformer's specific losses. For this reason electronic temperature measuring devices are normally provided. These are necessary to trigger the alarm or transformer protection. The following temperature sensors are available for Zucchini transformers: Pt100 thermosensors and PTC thermistors :

- **Pt100**: supplies a signal proportional to the temperature measured
- **PTC**: supplies an ON/OFF signal depending on whether the temperature measured is less or more than the sensor's threshold

The sensors are positioned in the hot point of the winding

Both the Pt100 and PTC signals must be processed by the temperature control unit, which does not form part of the standard equipment

On request other accessories are available to check the temperature :

- a separate temperature display, to be installed on the control panel
- an output relay for alarm and release and control of the fans

Maximum transformer alarm and release temperature values

Transformer type	Room (°C)	Alarm (°C)	Release (°C)
Resin	40	130	140

Temperature rise limits for cast resin transformers

Part	Insulating system temperature (°C)	Maximum temperature rises (K)
Windings : temperature rise measured with the heating element variation method	155 (F)	100
Core, metal parts and adjacent materials	–	In no case must the temperature reach values which would damage the core itself, other parts or adjacent materials

When combined with control sensors, the following can also be supplied, if required :

- T154 Unit or MT200 Unit : equipment used for controlling the Pt100 thermistors with temperature display, output relay for alarm, optional trip and control of the ventilation bars supplied as a detached part to be installed on the electric panel
- T119 Unit : equipment used for controlling the PTC thermistors with output relay for alarm, optional trip and control of the ventilation bars supplied for being installed on the electric panel

Ventilation accessories :

- Zucchini cast resin transformers can be equipped at the factory with special ventilation fans. These special tangential fans are designed to allow temporary and limited increase of the power delivered by the transformer, up to + 40% of the rated power

- VRT200 Unit : equipment for automatic activation and control of the fans

Green T.HE MV/LV cast resin transformers

technical information (continued)

■ Protection against overloads

Overload is the phenomenon which occurs when the value of current absorbed by the system is higher than the rated value. The persistence of an overload inevitably leads to exceeding the acceptable temperature rise limits specified for the transformer, with the consequent risk of deterioration of the insulating materials. Exceptionally, in certain abnormal service conditions, it may be acceptable to exceed the overload and temperature rise thresholds, to the detriment of the transformer's expected lifetime. This situation is sometimes preferable to an interruption of service (due to a temporary power peak) which could cause considerable material and economic damage. In most cases the overloads are transient and thus generally do not affect the thermal equilibrium. The 'acceptable' overload level is a function of the user's need for service continuity and the type of system itself. For insulating-liquid transformers the circulation of the cooling oil and the shape of the radiator containment tanks allow the rapid restoration of the insulation and the reduction of partial discharges, as well as allowing the transformer to reach its operating temperature quickly

Overload capacity of an oil transformer

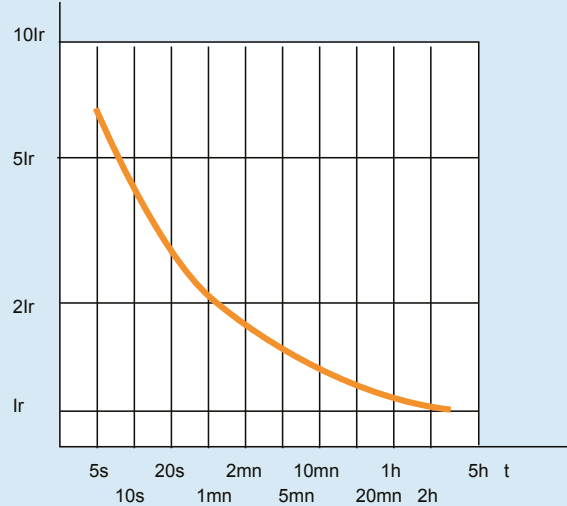

For cast resin transformers, the cooling component is air, and thus it takes longer to reach the operating temperature. In these conditions cast resin transformers may be more overloaded and thus may be used in systems with loads where there are frequent breakaway starting currents. This is true as long as the temperature rises on the windings do not remain above the allowable values for too long. A partial solution of the problem may be the use of radial fans affixed to the cast resin transformers, allowing a temporary transformer overload up to 140% of the rated power. It should, however, be remembered that as the power increases the losses due to load increase. As they depend on the square of the current they can reach up to 1.96 times the rated value. Radial fans should only be used in special and temporary cases to cool the windings or to have a sort of power reserve which may be used in emergency situations



Overload in public distribution

In public distribution, in the short term priority is given to continuity of service. For this reason overloads do not generally lead to switching the transformer "OFF". Again for the same reason generally low voltage circuits are always oversized and consequently an overload of the transformer never corresponds to an overload of the conductors. However, attention should be paid when the overloads repeat too frequently. In this situation the distributing organisation should replace the transformer with a model with greater power



Overload in industrial distribution

In an industrial installation, the overload can last for a short or long time. In these installations the main distribution board equipped with protective circuit breakers against overload and short-circuit is always immediately downstream of the transformers. Management of the overload is in fact delegated to the circuit breakers on the low voltage side which will detach the loads in an automatic or controlled way



Overload in service distribution

In service installations, such as offices and shopping centres, continuity of service is fundamental. In these types of application conditions of regular load, which have starting regimes or similar behaviour, rarely occur

To guarantee maximum continuity of service, even when there are overloads, it is essential that the loads considered non-priority are managed and disconnected when needed by the transformer on the low voltage side



■ **Protection against overloads by means of measuring the temperature**

As previously stated, overload is fundamentally associated to a temperature rise, which is the real component to be kept under control, because its effects could lead to the rapid deterioration of the insulation materials and to the failure of the transformer's dielectric properties. Verifying the temperature is a determining factor in protection of the transformer itself. To check the temperature therefore, cast resin transformers are generally equipped with thermoresistors, in turn connected to electronic control units, which signal or directly release the transformer when the defined thresholds are exceeded. Zucchini cast resin transformers have these thermoresistors installed near the parts which are most critical from the thermal point of view



Example of installation of a Pt100 temperature control unit



Fan control unit



Temperature control unit

■ **Certified quality**

Certifications

The Legrand test lab "IB03" has recently received the qualification by ACAE to work in accordance to IEC EN 17025 standard on all routine tests and on some tests for medium-voltage transformers. Such acknowledgement and qualification is a very important milestone obtained and Legrand, with a limited number of companies around the world, can offer this to their customers. All Legrand transformers are individually tested before being delivered to the customer.



Temperature rise limits for cast resin transformers	
Acceptance tests	
Measurement of the winding resistance	IEC 60076-11 (clause 14.2.1)
Measurement of voltage ratio and check of phase displacement	IEC 60076-11 (clause 14.2.2)
Measurement of short circuit impedance and load loss	IEC 60076-11 (clause 14.2.3)
Measurement of the no-load loss and the no-load current	IEC 60076-11 (clause 14.2.4)
Separate source AC withstand voltage test	IEC 60076-11 (clause 14.2.5)
Induced AC withstand voltage test	IEC 60076-11 (clause 14.2.6)
Measurement of the partial discharges	IEC 60076-11 (clause 14.2.7)
Type tests (on request)	
Atmospheric impulse test	IEC 60076-11 (clause 14.3.1)
Temperature rise test	IEC 60076-11 (clause 14.3.2)
Social tests (on request)	
Measurement of the noise level	IEC 60076-11 (clause 14.4.2)
Short circuit test	IEC 60076-11 (clause 14.4.3)

Thanks to the excellent quality of its transformers, Legrand offers to its customers the possibility of extending, upon request, the purchased product warranty.

Green T.HE MV/LV cast resin transformers

technical information (continued)

■ Extreme environmental conditions

The IEC 60076-11 standard identifies the environmental, climatic and fire behaviour classes of dry-type transformers with an alphanumeric code. Thanks to the use of high-quality epoxy resins, all Legrand transformers minimize environmental impact and comply with the following classes :

- **Environmental class E3¹**
- **Climate class C2**
- **Fire behaviour class F1**

This means that they can be stored, transported and above all used under extreme environmental conditions :

- Minimum room temperature: -25 °C
- Maximum relative humidity: 95%

Furthermore, in standard configuration, Green T.HE transformers guarantee a seismic resistance up to 0.2g² (light earthquakes) and can be fixed to the ground, thus avoiding any possibility of overturning

On request, Legrand manufactures transformers that can be installed in areas with higher seismic hazard, up to 0.5g (AG5)



E3
ENVIRONMENTAL TESTS

E0
No condensation on the transformer, negligible pollution, installation in a clean and dry environment

E1
Occasional condensation and limited pollution

E2
The transformer is subjected to frequent condensation, light pollution, or both

E3
The transformer is subjected to medium pollution and frequent condensation with humidity above 95%

E4
On request, Legrand is also able to supply transformers with E4 environmental classification for heavy pollution



C2
CLIMATE TESTS

C1
The transformer is suitable for operation at temperatures not below -5°C but may be exposed during transport and storage to temperatures down to -25°C.

C2
The transformer can operate, be transported and stored at temperatures as low as -25°C.



F1
RESISTANCE TO FIRE

F0
The risk of fire is not expected and no measures are taken to limit inflammability.

F1
The transformer is subject to the risk of fire and reduced inflammability is required. Fire on the transformer must be extinguished within laid-down limits.

The normal environmental service conditions are as follows:

- Maximum operating temperature: 40°C
- Monthly average temperature of the hottest month: 30°C
- Yearly average temperature: 20°C

1 : E4 is available on request, please contact us on +44 (0) 370 608 9020
2 : g = 9.81m/s² (gravitational acceleration)

■ Design criteria for Tier 2 material split

Legrand has always taken care of every detail relating to cast resin transformers to guarantee maximum performance to customers in terms of simplicity, safety and flexibility. The new design criteria adopted also go in the direction of creating added values in terms of environmental aspects. In compliance with regulations, the attention paid to new material technologies has led Legrand to play a primary role in reducing the environmental impact of dry-type transformers.

The following table shows the material of the components used in our products, useful to manage recycling operations, getting high-performance end-of-life recycling solutions.

Due to the manufacturing complexity of the product, the table below provides the main materials of which it is composed, and the relative quantity by weight. The precise data for each single transformer are indicated on the plate of the specific transformer itself.

Weights of the main transformer materials

Range	Conductor material aluminium (kg)	Core material CRGO (cold-rolled grain orientated steel) (kg)
up to 630 kVA	100 to 500	200 to 1 500
from 800 kVA to 1 600 kVA	500 to 1 100	1 300 to 2 700
from 2 000 kVA to 3 150 kVA	1 100 to 1 700	2 700 to 6 000

For its High Efficiency Green Transformers Legrand makes PEP (Product Environmental Profile) certificates available to offer customers environmentally friendly solutions



The main vector groups of transformers

Internal windings may be connected in star, triangle or zigzag
Depending on the connection method, the system of induced voltages on the low voltage side is out of phase with respect to the average voltage by angles which are multiples of 30°

The winding connection method is identified by 3 letters (upper case for the primary and lower case for the secondary) :

- Y** – star connection
- D** – triangle connection
- Z** – zigzag connection

Associated with these letters are identified numbers which represent the phase shift, dividing it into 4 groups :

- Group 0 – no phase shift
- Group 11 – 330°
- Group 6 – 180°
- Group 5 – 150°

The choice of the transformer switching ON unit is one of the important factors for determining the operating regime as a function of the load
The ideal condition is when the load is balanced on all the phases, but this condition is often impossible to obtain. For this reason one must know the phase shift between primary and secondary phases

The table below shows the typical insertion diagrams

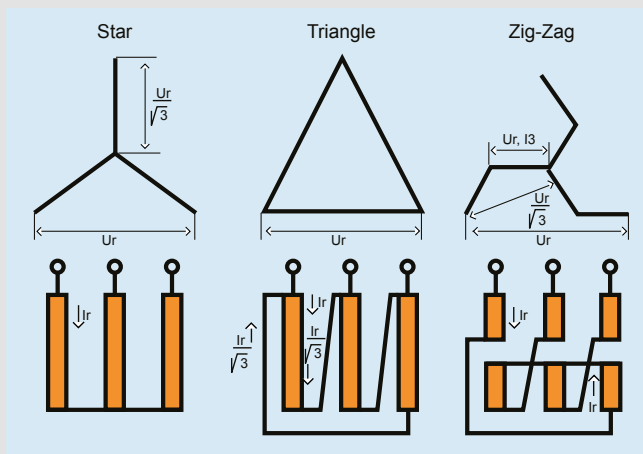
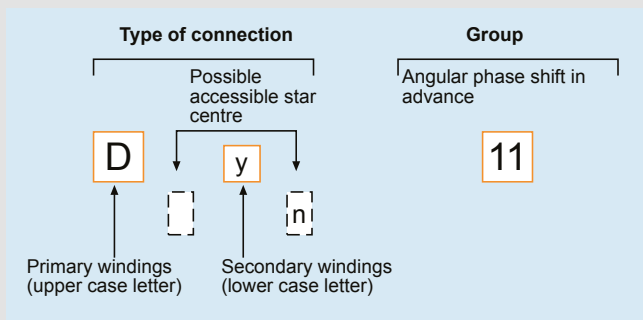

Special extended LV bar arrangements

The Legrand Group offer meets the needs of any installation
Cast resin transformers have specifically designed connections for Zucchini busbars

The versions shown represent some of the standard solutions for the outgoing busbar run from the transformer

Type A setup

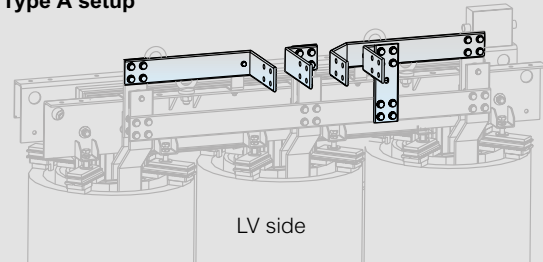

Type B setup

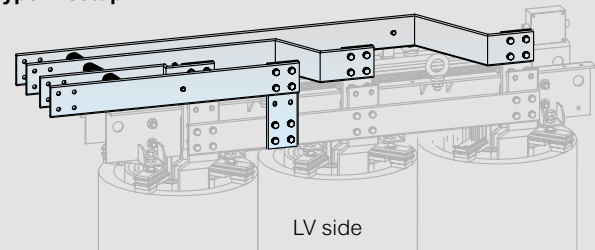

Type C setup

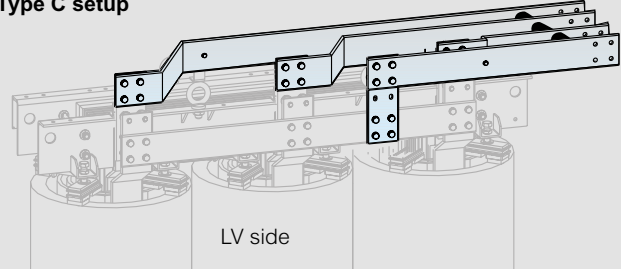

ATR connection interface

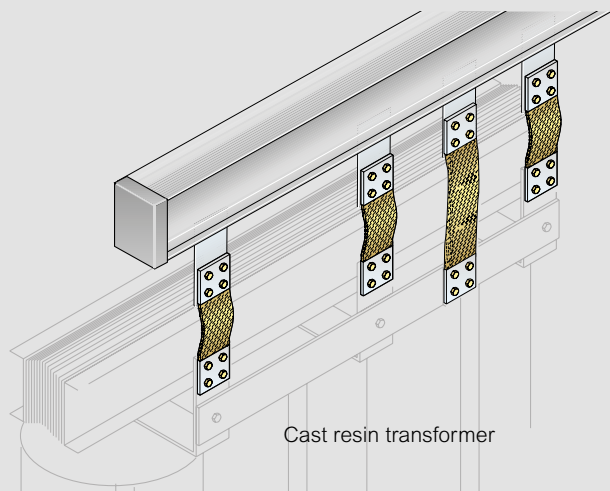

A technical drawing of the transformer is needed when creating an ATR connection interface

Extended MV bars are available on request, contact us on +44 (0) 370 608 9020

Green T.HE MV/LV cast resin transformers

technical information (continued)

Compatibility with Zucchini busbar

The Zucchini busbar trunking system and cast resin transformers have been designed in perfect synergy for a direct connection. The versions shown below represent just a few of the standardised solutions.

400 V secondary voltage

Transformer				Busbar (aluminium)	
kVA (kVA)	Insulation class (kV)	400 V current (A)	IK 6 % (kA)	Family	Connection component
630	12, 17-5, 24, 36	910	15-20	SCP 1 000 A	60281012P
800		1 155	19-30	SCP 1 250 A	60281014P
1 000		1 444	24-10	SCP 1 600 A	60281016P
1 250		1 805	30-10	SCP 2 000 A	60281017P
1 600		2 310	38-50	SCP 2 500 A	60391014P
2 000		2 887	48-20	SCP 3 200 A	60391016P
2 500		3 609	60-20	SCP 4 000 A	60391017P

Transformer				Busbar (copper)	
kVA (kVA)	Insulation class (kV)	400 V current (A)	IK 6 % (kA)	Family	Connection component
630	12, 17-5, 24, 36	910	15-20	SCP 1 000 A	65281011P
800		1 155	19-30	SCP 1 250 A	65281013P
1 000		1 444	24-10	SCP 1 600 A	65281015P
1 250		1 805	30-10	SCP 2 000 A	65281016P
1 600		2 310	38-50	SCP 2 500 A	65391018P
2 000		2 887	48-20	SCP 3 200 A	65391015P
2 500		3 609	60-20	SCP 4 000 A	65391016P
3 150	4 547	75-78	SCP 5 000 A	65391018P	

For full details on Legrand busbar systems see www.legrand.co.uk

417 V secondary voltage

Transformer				Busbar (aluminium)	
kVA (kVA)	Insulation class (kV)	417 V current (A)	IK 6 % (kA)	Family	Connection component
630	12, 17-5, 24, 36	873	14-60	SCP 1 000 A	60281012P
800		1 108	18-50	SCP 1 250 A	60281014P
1 000		1 385	23-10	SCP 1 600 A	60281016P
1 250		1 731	28-90	SCP 2 000 A	60281017P
1 600		2 216	37-00	SCP 2 500 A	60391014P
2 000		2 770	46-20	SCP 3 200 A	60391016P
2 500		3 462	57-70	SCP 4 000 A	60391017P

Transformer				Busbar (copper)	
kVA (kVA)	Insulation class (kV)	417 V current (A)	IK 6 % (kA)	Family	Connection component
630	12, 17-5, 24, 36	873	14-60	SCP 1 000 A	65281011P
800		1 108	18-50	SCP 1 250 A	65281013P
1 000		1 385	23-10	SCP 1 600 A	65281015P
1 250		1 731	28-90	SCP 2 000 A	65281016P
1 600		2 216	37-00	SCP 2 500 A	65391018P
2 000		2 770	46-20	SCP 3 200 A	65391015P
2 500		3 462	57-70	SCP 4 000 A	65391016P
3 150	4 362	72-70	SCP 5 000 A	65391018P	

433 V secondary voltage

Transformer				Busbar (aluminium)	
kVA (kVA)	Insulation class (kV)	433 V current (A)	IK 6 % (kA)	Family	Connection component
630	12, 17-5, 24, 36	841	14-10	SCP 1 000 A	60281012P
800		1 067	17-80	SCP 1 250 A	60281014P
1 000		1 334	22-30	SCP 1 600 A	60281016P
1 250		1 667	27-80	SCP 2 000 A	60281017P
1 600		2 134	35-60	SCP 2 500 A	60391014P
2 000		2 667	44-50	SCP 3 200 A	60391016P
2 500		3 334	55-60	SCP 4 000 A	60391017P

Transformer				Busbar (copper)	
kVA (kVA)	Insulation class (kV)	433 V current (A)	IK 6 % (kA)	Family	Connection component
630	12, 17-5, 24, 36	841	14-10	SCP 1 000 A	65281011P
800		1 067	17-80	SCP 1 250 A	65281013P
1 000		1 334	22-30	SCP 1 600 A	65281015P
1 250		1 667	27-80	SCP 2 000 A	65281016P
1 600		2 134	35-60	SCP 2 500 A	65391018P
2 000		2 667	44-50	SCP 3 200 A	65391015P
2 500		3 334	55-60	SCP 4 000 A	65391016P
3 150	4 201	70-02	SCP 5 000 A	65391018P	

Transformer to busbar connection

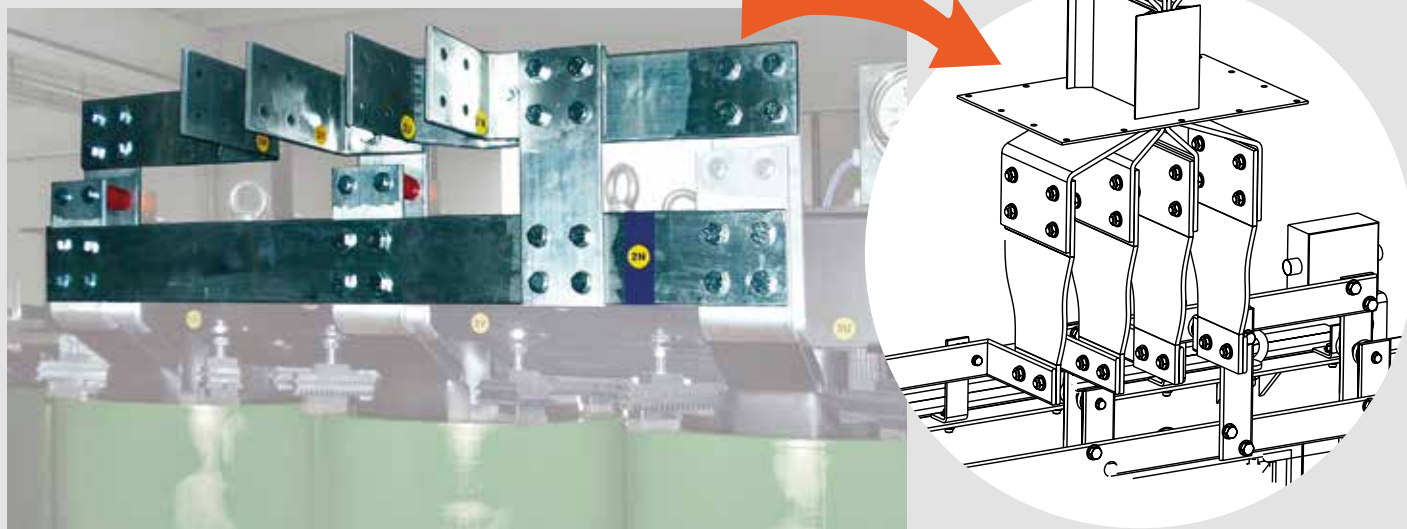

ZUCCHINI XCP



fast, simple
installation saves
time and money

INSTALLATION SIMPLICITY

Designed to work perfectly in conjunction with Zucchini's cast resin transformers, the XCP busbar range offers quick, reliable assembly with a vast combination of accessories for maximum flexibility. Conductors are available in a choice of copper or aluminium.

PLANNING SIMPLICITY

A comprehensive range of standard products is further enhanced by Legrand's technical expertise and ability to create bespoke solutions tailored to any requirements. The XCP range can be manufactured in standard, clean earth or 200% neutral versions.

The XCP range is available in two versions:

XCP-S Standard - Meeting the requirements of IEC 61439-6

XCP-HP High performance - Exceeding the requirements of IEC 61439-6



TO FIND OUT MORE CALL OUR TECHNICAL SUPPORT TEAM ON
+44 (0) 370 608 9020



Contact details

Quotations and Technical Support:

Legrand Electric Ltd.

Great King Street North,
Birmingham, B19 2LF

Tel: +44 (0) 370 608 9020

E-mail: powersales.uk@legrand.co.uk

Customer Services:

Tel: +44 (0) 345 605 4333

E-mail: powersales.uk@legrand.co.uk



FOLLOW
US AT



www.legrand.co.uk
www.legrand.ie



www.youtube.com/legrandtvuk



www.voltimum.co.uk
www.voltimum.ie



www.twitter.com/legranduk



[www.linkedin.com/
company/legranduk](http://www.linkedin.com/company/legranduk)



Head office (UK and Ireland):

Legrand Electric Limited

Great King Street North, Birmingham, B19 2LF

Tel: +44 (0) 370 608 9000 Fax: +44 (0) 370 608 9004

Website: www.legrand.co.uk

In accordance with its policy of continuous improvement, the Company reserves the right to change specifications and designs without notice. All illustrations, descriptions, dimensions and weights in this catalogue are for guidance and cannot be held binding on the Company. All contents and design presentation included in this publication are © Legrand Electric Limited. All rights reserved. 2021



This document is printed on sustainably sourced paper. Please recycle.

The Legrand logo is a registered trademark of the Legrand group of companies.