



# POWERTRACK

adaptable, reliable

underfloor power

## THE INDUSTRY STANDARD IN UNDERFLOOR POWER

Electrak powertrack / underfloor busbar is perfect for cavity floor installations. With minimal parts, push-fit assembly and a complementary range of floor boxes and grommets, this flexible, easy-to-install system can be reconfigured as office layouts evolve.

The system consists of continuous lengths of track which are fed via a feed unit and can be installed in floor voids as low as 48mm.

- 63 A rated, IP 40 protection
- Available in five versions: single phase, clean earth, dual circuit, three phase and auxiliary earth
- Tinned busbar version available for use within Abu Dhabi (see page 15)
- Available in 1.2 m, 1.8 m, 2.4 m and 3.6 m lengths
- Tap-off outlets are located at every 300 or 600 mm pitch
- Floor mountable (stand-off brackets also available)



Integral track connector plugs into feed unit



Lengths simply push-fit together



Integral fixing brackets for rapid installation















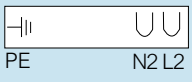

Tap-offs plug into shuttered socket outlets and lock onto track body

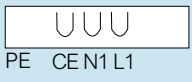
# Electrak® powertrack / underfloor busbar system

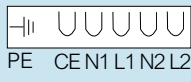
## selection chart

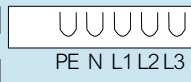
	Description	Length (m)	
<b>Track lengths with 300 mm socket centres</b>			
	4 outlets	1-2	
	6 outlets	1-8	
	8 outlets	2-4	
	12 outlets	3-6	
<b>Track feeds</b>			
		-	
	Excluding cables and conduit	-	
	Flexible metal conduit	1-2	
	Flexible metal conduit	2-4	
<b>Standard tap-off / auxiliary earth tap-off</b>			
	32 A unfused 16 mm Ø L, N, PE	3	
		5	
	13 A fused 16 mm Ø L, N, PE	3	
		5	
	13 A 543-7 fused 16 mm Ø L, N, PE	3	
		5	
<b>Low noise / clean earth tap-off</b>			
	32 A unfused 16 mm Ø CE, L, N, PE	3	
		5	
	13 A fused 16 mm Ø CE, L, N, PE	3	
		5	
	13 A 543-7 fused 16 mm Ø CE, L, N, PE	3	
		5	
<b>Dual circuit tap-off</b>			
	32 A unfused 20 mm Ø CE, L1, N1 L2, N2, PE	3	
		5	
<b>3 phase tap-off</b>			
	32 A 415 V 3 phase 20 mm Ø L1, L2, L3, N, PE	3	
		5	
	32 A L1 unfused reconfigurable live pin 16 mm Ø L1, N, PE	3	
		5	
	32 A L2 unfused reconfigurable live pin 16 mm Ø L2, N, PE	3	
		5	
	32 A L3 unfused reconfigurable live pin 16 mm Ø L3, N, PE	3	
		5	
	Key code / Busbar arrangement		

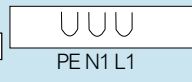
	<b>ELECTRAK 24</b> Standard system (white)		<b>ELECTRAK 25</b> Low noise / clean earth system (green)		<b>ELECTRAK 26</b> Dual circuit system (dark green)		<b>ELECTRAK 27</b> 3 phase system (grey)		<b>ELECTRAK 28</b> Auxiliary earth system (red)
	DA1123		JA2123		KA3123		NA4123		YA5123
	DA1183		JA2183		KA3183		NA4183		YA5183
	DA1243		JA2243		KA3243		NA4243		YA5243
	DA1363		JA2363		KA3363		NA4363		YA5363
	DF1010		JF2010		KF3010		NF4010		YF5010
	DW1000		JW2000		KW3000		NW4000		YW5000
	DW1010		JW2010		KW3010		NW4010		YW5010
	DW1020		JW2020		KW3020		NW4020		YW5020
	DP1332		–		DP1332		–		YP5332
	DP1532		–		DP1532		–		YP5532
	DP1313		–		DP1313		–		YP5313
	DP1513		–		DP1513		–		YP5513
	DP1327		–		DP1327		–		YP5327
	DP1527		–		DP1527		–		YP5527
	–		JP2332		JP2332		–		–
	–		JP2532		JP2532		–		–
	–		JP2313		JP2313		–		–
	–		JP2513		JP2513		–		–
	–		JP2327		JP2327		–		–
	–		JP2527		JP2527		–		–
	–		–		KP3328		–		–
	–		–		KP3528		–		–
	–		–		–		NZ4331		–
	–		–		–		NZ4531		–
	–		–		–		NP4332 <sup>1</sup>		–
	–		–		–		NP4532 <sup>1</sup>		–
	–		–		–		NP4302 <sup>1</sup>		–
	–		–		–		NP4502 <sup>1</sup>		–
	–		–		–		NP4303 <sup>1</sup>		–
	–		–		–		NP4503 <sup>1</sup>		–
									

1 : All NP tap-offs are reconfigurable between L1, L2 or L3 for 3 phase track

# Electrak® 24 powertrack / underfloor busbar system

standard system (white)

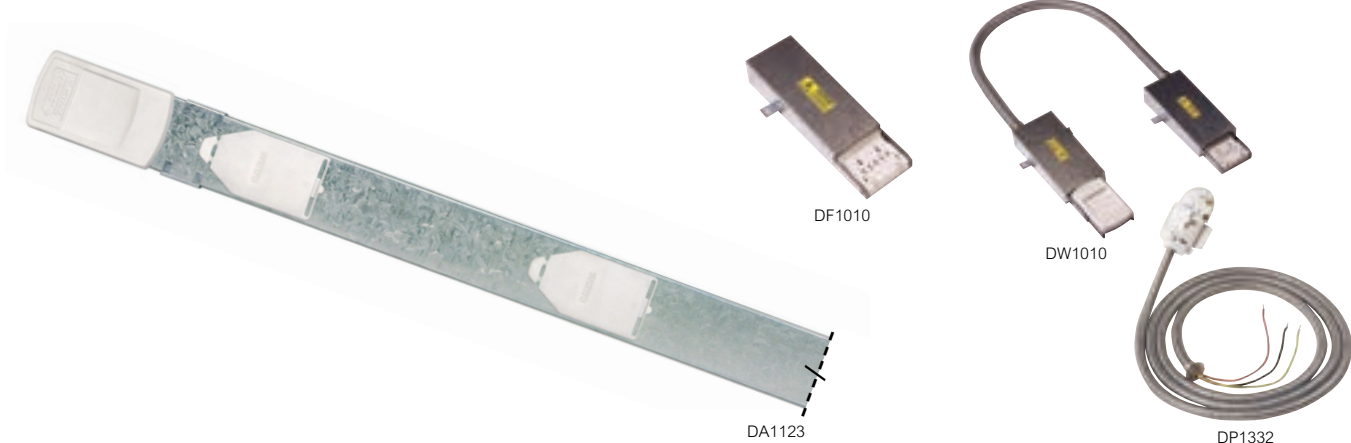

Selection charts **p. 8-9**  
Dimensions and technical information **p. 18-23**

Approved to ISO 9001  
Conforms to BS EN 61534-22. Fully complies with the requirements of BS 7671  
A compact system that can be installed in floor voids as low as 48 mm

Pack	Cat. Nos.	Track system components	Pack	Cat. Nos.	Tap-off units
		<b>Electrak 24 standard track lengths</b> Track lengths fit together using the integral connectors on each length Track lengths should always be secured using the integral floor fixing brackets 300 mm socket centres			Tap-off length is determined by the cable and not the conduit length, e.g. a 3 m tap-off has 3 m of cable and 2.6 m of flexible metal conduit! Tap-off units in excess of 3 m should only be used if they contain a fuse or if the powertrack is protected by a protective device not exceeding 32 A
1	DA1123	1.2 m, 4 outlets, 2 floor fixing brackets			<b>32 A unfused - 543-7 high integrity</b> 16 mm Ø, L, N, PE
1	DA1183	1.8 m, 6 outlets, 2 floor fixing brackets	1	DP1332	3 m
1	DA1243	2.4 m, 8 outlets, 2 floor fixing brackets	1	DP1532	5 m
1	DA1363	3.6 m, 12 outlets, 3 floor fixing brackets			<b>13 A fused - 543-7 high integrity</b> 16 mm Ø, L, N, PE
		<b>Track feed unit</b> With one 25 mm diameter hole suitable for MICC, armoured cables or single core cables in conduit	1	DP1327	3 m
		<b>Flexible interlinks</b> Can be used to overcome obstructions or as corners where required	1	DP1527	5 m
1	DW1000	Excluding cables and conduit			<b>13 A fused</b> 16 mm Ø, L, N, PE
1	DW1010	1.2 m flexible metal conduit	1	DP1313	3 m
1	DW1020	2.4 m flexible metal conduit	1	DP1513	5 m
		<b>Special fixing brackets</b> Required when track is raised off surface level Brackets raise track by 21 mm and should be spaced 600 mm apart			<b>Tap-off units specifically for the U.A.E.</b> To meet the local requirements, these tap-offs contain silver-flashed blades, larger 20 mm Ø conduits and minimum 4 mm <sup>2</sup> conductors
1	DZ1210	For fitting under track body and track feed	1	DP1332R	3 m U.A.E.
1	DZ1230	For fitting under integral track connectors	1	DP1532R	5 m U.A.E.
					<b>32 A unfused - 543-7 high integrity</b> L (red), N (black), PE (green/yellow)
					<b>13 A fused - 543-7 high integrity</b> L (red), N (black), PE (green/yellow)
			1	DP1314R	3 m U.A.E.
			1	DP1514R	5 m U.A.E.

1 : Tap-offs are supplied as standard with flexible metal conduit  
For alternative wiring solutions, contact us on +44 (0) 370 608 9020

# Electrak® 25 powertrack / underfloor busbar system

low noise / clean earth system (green)

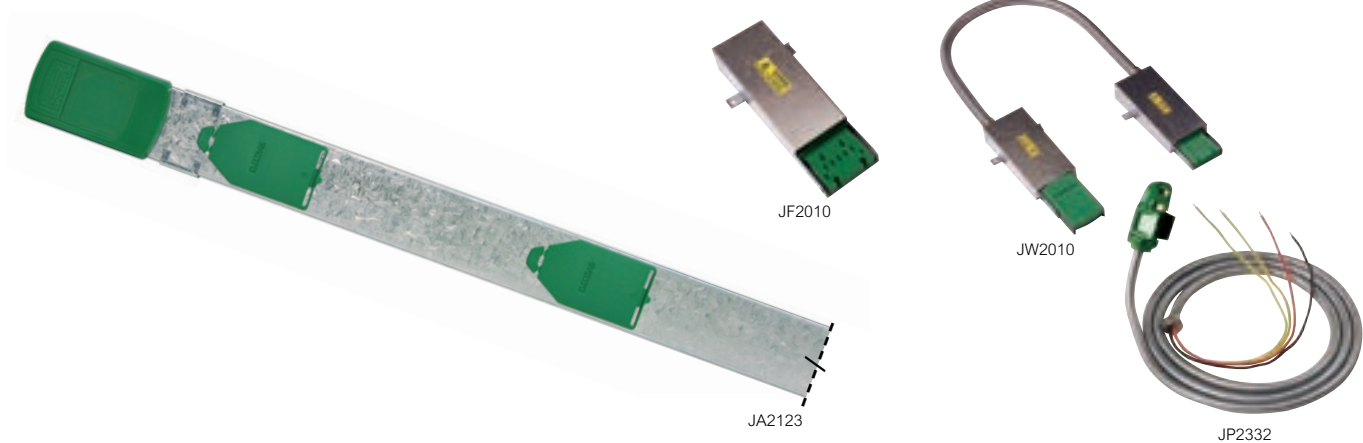

 Selection charts **p. 8-9**  
Dimensions and technical information **p. 18-23**

Approved to ISO 9001  
Conforms to BS EN 61534-22. Fully complies with the requirements of BS 7671  
A compact system that can be installed in floor voids as low as 48 mm

Pack	Cat. Nos.	Track system components
		<b>Electrak 25 low noise / clean earth track lengths</b> Track lengths fit together using the integral connectors on each length Track lengths should always be secured using the integral floor fixing brackets 300 mm socket centres
1	JA2123	1.2 m, 4 outlets, 2 floor fixing brackets
1	JA2183	1.8 m, 6 outlets, 2 floor fixing brackets
1	JA2243	2.4 m, 8 outlets, 2 floor fixing brackets
1	JA2363	3.6 m, 12 outlets, 3 floor fixing brackets
		<b>Track feed unit</b>
1	JF2010	With one 25 mm diameter hole suitable for MICC, armoured cables or single core cables in conduit
		<b>Flexible interlinks</b> Can be used to overcome obstructions or as corners where required
1	JW2000	Excluding cables and conduit
1	JW2010	1.2 m flexible metal conduit
1	JW2020	2.4 m flexible metal conduit
		<b>Special fixing brackets</b> Required when track is raised off surface level Brackets raise track by 21 mm and should be spaced 600 mm apart
1	DZ1210	For fitting under track body and track feed
1	DZ1230	For fitting under integral track connectors

Pack	Cat. Nos.	Tap-off units
		Tap-off length is determined by the cable and not the conduit length, e.g. a 3 m tap-off has 3 m of cable and 2.6 m of flexible metal conduit <sup>1</sup> Tap-off units in excess of 3 m should only be used if they contain a fuse or if the powertrack is protected by a protective device not exceeding 32 A
		<b>32 A unfused - 543-7 high integrity</b> 16 mm Ø, CE, L, N, PE
1	JP2332	3 m
1	JP2532	5 m
		<b>13 A fused - 543-7 high integrity</b> 16 mm Ø, CE, L, N, PE
1	JP2327	3 m
1	JP2527	5 m
		<b>13 A fused</b> 16 mm Ø, CE, L, N, PE
1	JP2313	3 m
1	JP2513	5 m

<sup>1</sup> : Tap-offs are supplied as standard with flexible metal conduit  
For alternative wiring solutions, contact us on +44 (0) 370 608 9020

# Electrak® 26 powertrack / underfloor busbar system

dual circuit system (dark green)

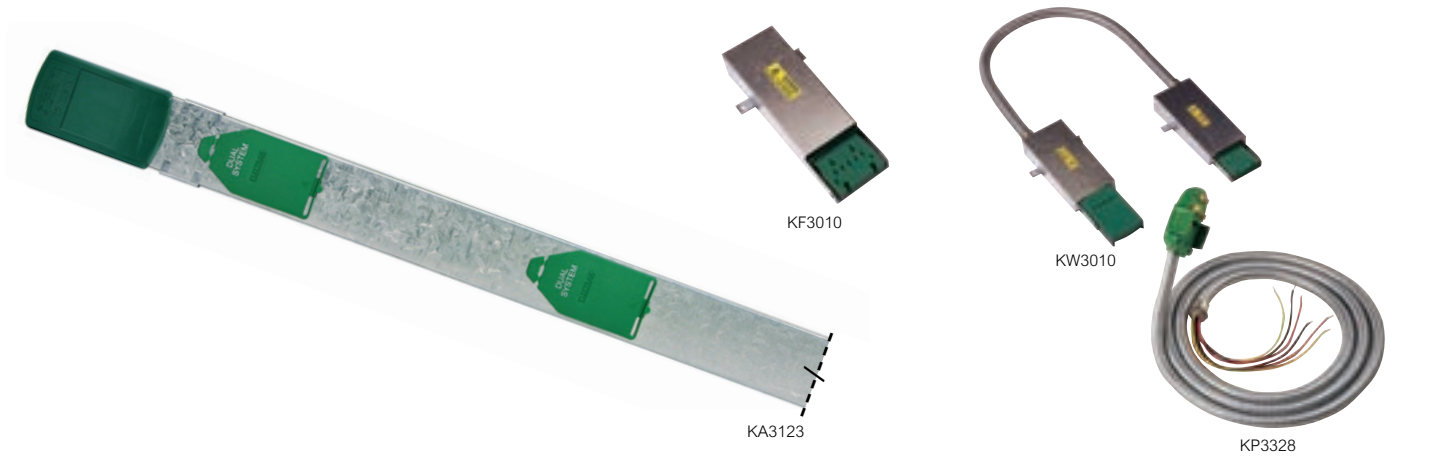

Selection charts **p. 8-9**  
Dimensions and technical information **p. 18-23**

Approved to ISO 9001  
Conforms to BS EN 61534-22. Fully complies with the requirements of BS 7671  
A compact system that can be installed in floor voids as low as 48 mm

Pack	Cat. Nos.	Track system components
		The dual powertrack system has both standard and low noise / clean earth systems incorporated
		<b>Electrak 26 dual circuit track lengths</b>
		Track lengths fit together using the integral connectors on each length
		Track lengths should always be secured using the integral floor fixing brackets
		300 mm socket centres
1	KA3123	1.2 m, 4 outlets, 2 floor fixing brackets
1	KA3183	1.8 m, 6 outlets, 2 floor fixing brackets
1	KA3243	2.4 m, 8 outlets, 2 floor fixing brackets
1	KA3363	3.6 m, 12 outlets, 3 floor fixing brackets
		<b>Track feed unit</b>
1	KF3010	With two 25 mm diameter holes suitable for MICC, armoured cables or single core cables in conduit
		<b>Flexible interlinks</b>
		Can be used to overcome obstructions or as corners where required
1	KW3000	Excluding cables and conduit
1	KW3010	1.2 m flexible metal conduit
1	KW3020	2.4 m flexible metal conduit
		<b>Special fixing brackets</b>
		Required when track is raised off surface level
		Brackets raise track by 21 mm and should be spaced 600 mm apart
1	DZ1210	For fitting under track body and track feed
1	DZ1230	For fitting under integral track connectors

Pack	Cat. Nos.	Tap-off units
		Tap-off length is determined by the cable and not the conduit length, e.g. a 3 m tap-off has 3 m of cable and 2.6 m of flexible metal conduit <sup>1</sup>
		Tap-off units in excess of 3 m should only be used if they contain a fuse or if the powertrack is protected by a protective device not exceeding 32 A
		<b>Standard 32 A unfused - 543-7 high integrity</b>
		16 mm Ø, L, N, PE
1	DP1332	3 m
1	DP1532	5 m
		<b>Standard 13 A fused - 543-7 high integrity</b>
		16 mm Ø, L, N, PE
1	DP1327	3 m
1	DP1527	5 m
		<b>Standard 13 A fused</b>
		16 mm Ø, L, N, PE
1	DP1313	3 m
1	DP1513	5 m
		<b>Low noise / clean earth 32 A unfused - 543-7 high integrity</b>
		16 mm Ø, CE, L, N, PE
1	JP2332	3 m
1	JP2532	5 m
		<b>Low noise / clean earth 13 A fused - 543-7 high integrity</b>
		16 mm Ø, CE, L, N, PE
1	JP2327	3 m
1	JP2527	5 m
		<b>Low noise / clean earth 13 A fused</b>
		16 mm Ø, CE, L, N, PE
1	JP2313	3 m
1	JP2513	5 m
		<b>Dual circuit 32 A unfused - 543-7 high integrity</b>
		20 mm Ø, CE, L1, N1, L2, N2, PE
1	KP3328	3 m
1	KP3528	5 m

<sup>1</sup> : Tap-offs are supplied as standard with flexible metal conduit  
For alternative wiring solutions, contact us on +44 (0) 370 608 9020

# Electrak® 27 powertrack / underfloor busbar system

3 phase system (grey)

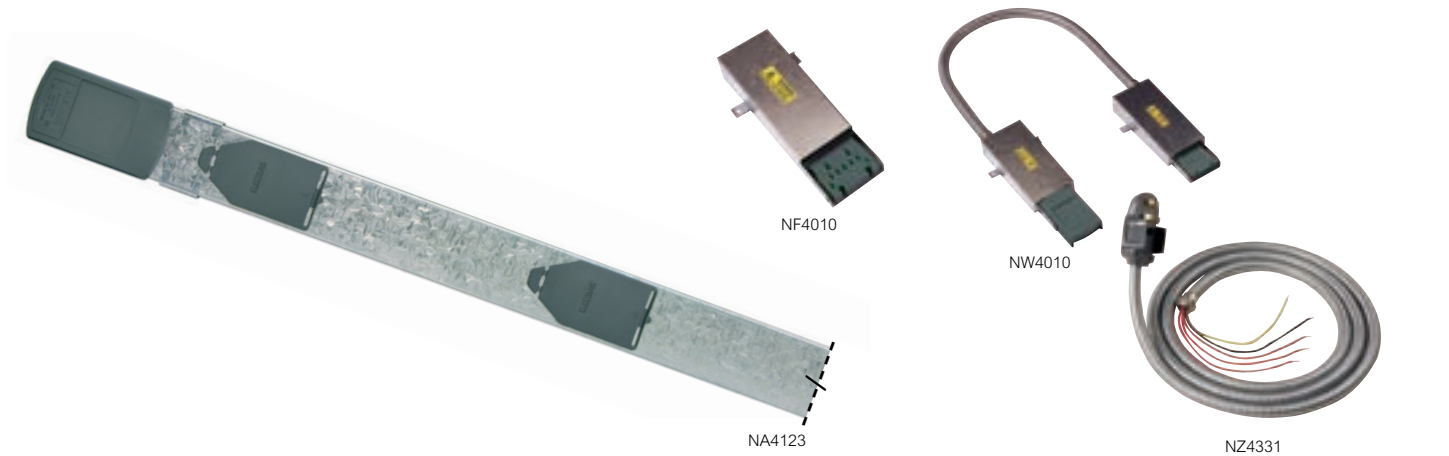

 Selection charts **p. 8-9**  
Dimensions and technical information **p. 18-23**

Approved to ISO 9001  
Conforms to BS EN 61534-22. Fully complies with the requirements of BS 7671  
A compact system that can be installed in floor voids as low as 48 mm

Pack	Cat. Nos.	Track system components
		<b>Electrak 27 3 phase track lengths</b> Track lengths fit together using the integral connectors on each length Track lengths should always be secured using the integral floor fixing brackets 300 mm socket centres
1	NA4123	1.2 m, 4 outlets, 2 floor fixing brackets
1	NA4183	1.8 m, 6 outlets, 2 floor fixing brackets
1	NA4243	2.4 m, 8 outlets, 2 floor fixing brackets
1	NA4363	3.6 m, 12 outlets, 3 floor fixing brackets
		<b>Track feed unit</b> With one 25 mm diameter hole suitable for MICCC, armoured cables or single core cables in conduit
1	NF4010	
		<b>Flexible interlinks</b> Can be used to overcome obstructions or as corners where required
1	NW4000	Excluding cables and conduit
1	NW4010	1.2 m flexible metal conduit
1	NW4020	2.4 m flexible metal conduit
		<b>Special fixing brackets</b> Required when track is raised off surface level Brackets raise track by 21 mm and should be spaced 600 mm apart
1	DZ1210	For fitting under track body and track feed
1	DZ1230	For fitting under integral track connectors

Pack	Cat. Nos.	Tap-off units
		Tap-off length is determined by the cable and not the conduit length, e.g. a 3 m tap-off has 3 m of cable and 2.6 m of flexible metal conduit <sup>1</sup> Tap-off units in excess of 3 m should only be used if they contain a fuse or if the powertrack is protected by a protective device not exceeding 32 A
		<b>32 A 415 V 3 phase - 543-7 high integrity</b> 20 mm Ø, L1, L2, L3, N, PE
1	NZ4331	3 m
1	NZ4531	5 m
		<b>32 A L1<sup>2</sup> unfused - 543-7 high integrity</b> Reconfigurable live pin 16 mm Ø, L, N, PE
1	NP4332	3 m
1	NP4532	5 m
		<b>32 A L2<sup>2</sup> unfused - 543-7 high integrity</b> Reconfigurable live pin 16 mm Ø, L, N, PE
1	NP4302	3 m
1	NP4502	5 m
		<b>32 A L3<sup>2</sup> unfused - 543-7 high integrity</b> Reconfigurable live pin 16 mm Ø, L, N, PE
1	NP4303	3 m
1	NP4503	5 m
		<b>Tap-off units specifically for the U.A.E.</b> To meet the local requirements, these tap-offs contain silver-flashed blades, larger 20 mm Ø conduits, minimum 4 mm <sup>2</sup> conductors and use RYB colour coding for the conductors
		<b>32 A unfused - 543-7 high integrity</b>
1	NP4332R	3 m L1 U.A.E. (R)
1	NP4532R	5 m L1 U.A.E. (R)
1	NP4302Y	3 m L2 U.A.E. (Y)
1	NP4502Y	5 m L2 U.A.E. (Y)
1	NP4303B	3 m L3 U.A.E. (B)
1	NP4503B	5 m L3 U.A.E. (B)

1 : Tap-offs are supplied as standard with flexible metal conduit  
For alternative wiring solutions, contact us on +44 (0) 370 608 9020  
2 : All NP tap-offs are reconfigurable between L1, L2, or L3 for 3 phase track



# Electrak® 28 powertrack / underfloor busbar system

## auxiliary earth system (red)

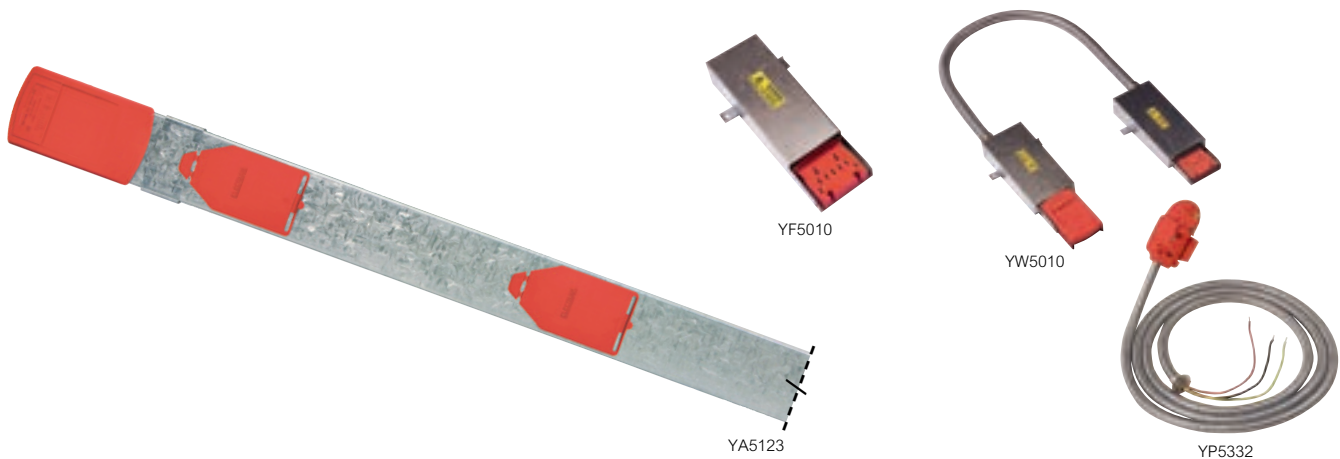

Selection charts **p. 8-9**  
Dimensions and technical information **p. 18-23**

Approved to ISO 9001  
Conforms to BS EN 61534-22. Fully complies with the requirements of BS 7671  
A compact system that can be installed in floor voids as low as 48 mm

Pack	Cat. Nos.	Track system components	Pack	Cat. Nos.	Tap-off units
		<b>Electrak 28 auxiliary earth track lengths</b>			Tap-off length is determined by the cable and not the conduit length, e.g. a 3 m tap-off has 3 m of cable and 2.6 m of flexible metal conduit <sup>1</sup> Tap-off units in excess of 3 m should only be used if they contain a fuse or if the powertrack is protected by a protective device not exceeding 32 A
		Track lengths fit together using the integral connectors on each length Track lengths should always be secured using the integral floor fixing brackets 300 mm socket centres			<b>32 A unfused - 543-7 high integrity</b>
1	YA5123	1.2 m, 4 outlets, 2 floor fixing brackets			16 mm Ø, L, N, PE
1	YA5183	1.8 m, 6 outlets, 2 floor fixing brackets	1	YP5332	3 m
1	YA5243	2.4 m, 8 outlets, 2 floor fixing brackets	1	YP5532	5 m
1	YA5363	3.6 m, 12 outlets, 3 floor fixing brackets			<b>13 A fused - 543-7 high integrity</b>
		<b>Track feed unit</b>			16 mm Ø, L, N, PE
1	YF5010	With one 25 mm diameter hole suitable for MICC, armoured cables or single core cables in conduit	1	YP5327	3 m
		<b>Flexible interlinks</b>	1	YP5527	5 m
		Can be used to overcome obstructions or as corners where required			<b>13 A fused</b>
1	YW5000	Excluding cables and conduit			16 mm Ø, L, N, PE
1	YW5010	1.2 m flexible metal conduit	1	YP5313	3 m
1	YW5020	2.4 m flexible metal conduit	1	YP5513	5 m
		<b>Special fixing brackets</b>			
		Required when track is raised off surface level Brackets raise track by 21 mm and should be spaced 600 mm apart			
1	DZ1210	For fitting under track body and track feed			
1	DZ1230	For fitting under integral track connectors			

<sup>1</sup> : Tap-offs are supplied as standard with flexible metal conduit  
For alternative wiring solutions, contact us on +44 (0) 370 608 9020

# Electrak tinned powertrack...

Designed to meet  
local standards

Guideline For Design, Testing and Installation Of Busways GL.GN.01.

Issued by: Abu Dhabi Distribution Co.

Low Voltage Switchgear Committee

Issue: 2, Revision: 1, effective 01/02/2012

16. Lighting & Small Power Busways & Modular Wiring  
Lighting & Power Socket bus duct and modular wiring are considered part of building wiring and regulated by the Electricity Wiring Regulation issued by RSB. It shall comply with respective specifications under the Wiring regulation. ADDC LVSGC approves these methods in principle provided that the RSB set aspects are incorporated (like tinning of copper, colour coding etc.).

**Guideline For Design, Testing and Installation Of Busways GL.GN.01**

Copyright Abu Dhabi Distribution Co.

Developed to meet the ADDC requirements for busways, these specially designed ranges see all busbars tinned along their entire length, and all busbar connectors and tap-off blades plated.

Approved and designed to be in accordance with the requirements of BS EN 61439-6 and BS EN 61534-22 (IEC 61534).

**The Electrical Wiring Regulations 2007**  
Issued by: The Regulation and Supervision Bureau for the Water, Wastewater and Electricity Sector in the Emirate of Abu Dhabi. Revision 1, January 2009

7.7 Busways, bus ducts and busbar risers  
7.7.6 Busways, bus ducts and busbar risers shall have neutral conductors of equal size to the phase conductors and shall have a dedicated Earth Conductor. The use of the metal casing as an earth conductor permitted only for Earth Leakage Protected Installations, and with the prior approval of the Distribution Company.

**The Electrical Wiring Regulations 2007**

Copyright The Regulation and Supervision Bureau (RSB)

The Electrak powertrack system uses equal size tinned copper busbars for live, neutral and earth conductors to meet with the requirements of The Regulation and Supervision Bureau of the Water, Wastewater and Electricity Sector in the Emirate of Abu Dhabi.

As a specific requirement for use within Abu Dhabi, Legrand has developed a 'tinned' busbar which has been designed in line with the guidance for busways outlined by the Abu Dhabi Distribution Company (ADDC), as detailed below.



Electrak 28R tinned tap-offs



Electrak 28R tinned busbar connectors

**Appendix 8.** Colour identification for cables

Conductor	Colour
<b>Non-flexible fixed wiring and all 3 phase cables:</b>	
Phase 1	Red
Phase 2	Yellow
Phase 3	Blue
Neutral	Black
Earth conductors	Green / yellow

To meet the local regulations, tap-offs designed for sale within this region are supplied with the following cable colours:

Within any single phase system (e.g. Electrak 25R or Electrak 28R) - red (L), black (N) and green/yellow (E).

Specifically within the 3 phase Electrak 27 system - L1 tap-offs are red (L), black (N) and green/yellow (E); L2 tap-offs are yellow (L), black (N) and green/yellow (E); L3 tap-offs are blue (L), black (N) and green/yellow (E).

**Appendix 9.** Capacity of conduits and trunking

Conduit (mm <sup>2</sup> )	Diameter of Conduit (mm <sup>2</sup> )		
	20	25	32
<b>Maximum number of conductors</b>			
1.5	7	12	-
2.5	5	9	12
4.0	3	6	9

The tap-offs contain a maximum of 2 x 4 mm<sup>2</sup> conductors (excluding earths) housed in a 20 mm ø metal flexible conduit.

**NOTE:** When designing installation in regions with higher ambient temperatures than 35°C, de-rating factors may need to be applied. Please refer to the table on page 22 for details.



# Electrak® 25R tinned powertrack / underfloor busbar system

low noise / clean earth system (green)

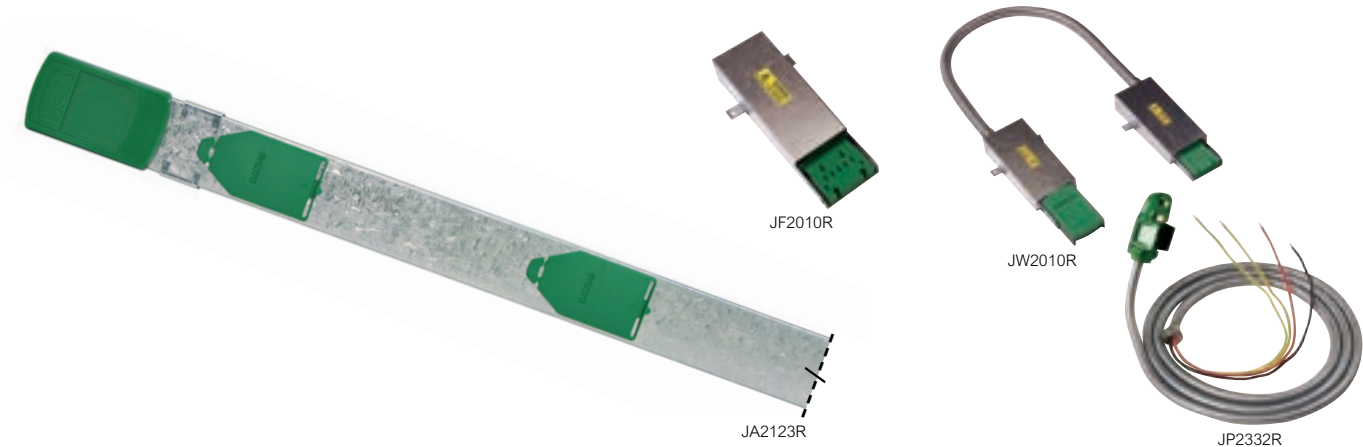

Dimensions and technical information p. 18-23

Approved to ISO 9001  
 Conforms to BS EN 61534-22. Fully complies with the requirements of BS 7671  
 A compact system that can be installed in floor voids as low as 48 mm

Pack	Cat. Nos.	Busbar system components
		<b>63 A low noise / clean earth busbar lengths</b> Busbar lengths fit together using the integral connectors on each length Lengths should always be secured using the integral floor fixing brackets 300 mm socket centres
1	JA2123R	1.2 m, 4 outlets, 2 floor fixing brackets
1	JA2183R	1.8 m, 6 outlets, 2 floor fixing brackets
1	JA2243R	2.4 m, 8 outlets, 2 floor fixing brackets
1	JA2363R	3.6 m, 12 outlets, 3 floor fixing brackets
		<b>Feed unit</b>
1	JF2010R	With one 25 mm diameter hole suitable for MICC, armoured cables or single core cables in conduit
		<b>Flexible interlinks</b> Can be used to overcome obstructions or as corners where required
1	JW2000R	Excluding cables and conduit
1	JW2010R	1.2 m flexible metal conduit
1	JW2020R	2.4 m flexible metal conduit
		<b>Special fixing brackets</b> Required when busbar is raised off surface level Brackets raise the system by 21 mm and should be spaced 600 mm apart
1	DZ1210	For fitting under lengths and feed units
1	DZ1230	For fitting under integral connectors

Pack	Cat. Nos.	Tap-off units
		Tap-off length is determined by the cable and not the conduit length, e.g. a 3 m tap-off has 3 m of cable and 2.6 m of flexible metal conduit <sup>1</sup> Tap-off units in excess of 3 m should only be used if they contain a fuse or if the busbar run is protected by a protective device not exceeding 32 A
		<b>32 A unfused - 543-7 high integrity</b> 20 mm Ø, CE, L, N, PE (4 mm <sup>2</sup> )
1	JP2332R	3 m
1	JP2532R	5 m
		<b>13 A fused - 543-7 high integrity</b> 20 mm Ø, CE, L, N, PE (4 mm <sup>2</sup> )
1	JP2314R	3 m
1	JP2514R	5 m

<sup>1</sup> : Tap-offs are supplied as standard with flexible metal conduit  
 For alternative wiring solutions, contact us on +44 (0) 370 608 9020

# Electrak® 28R tinned powertrack / underfloor busbar system

## auxiliary earth system (red)

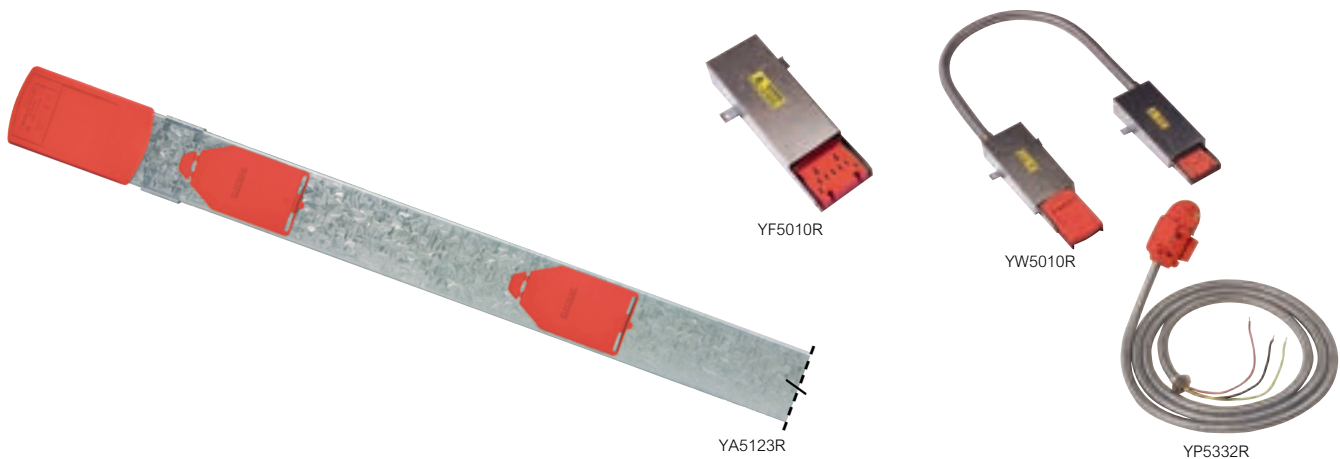

 Dimensions and technical information p. 18-23

Approved to ISO 9001  
 Conforms to BS EN 61534-22. Fully complies with the requirements of BS 7671  
 A compact system that can be installed in floor voids as low as 48 mm

Pack	Cat. Nos.	Busbar system components
		<b>63 A auxiliary earth busbar lengths</b>
		Busbar lengths fit together using the integral connectors on each length Lengths should always be secured using the integral floor fixing brackets 300 mm socket centres
1	YA5123R	1.2 m, 4 outlets, 2 floor fixing brackets
1	YA5183R	1.8 m, 6 outlets, 2 floor fixing brackets
1	YA5243R	2.4 m, 8 outlets, 2 floor fixing brackets
1	YA5363R	3.6 m, 12 outlets, 3 floor fixing brackets
		<b>Feed unit</b>
1	YF5010R	With one 25 mm diameter hole suitable for MICC, armoured cables or single core cables in conduit
		<b>Flexible interlinks</b>
		Can be used to overcome obstructions or as corners where required
1	YW5000R	Excluding cables and conduit
1	YW5010R	1.2 m flexible metal conduit
1	YW5020R	2.4 m flexible metal conduit
		<b>Special fixing brackets</b>
		Required when busbar is raised off surface level Brackets raise the system by 21 mm and should be spaced 600 mm apart
1	DZ1210	For fitting under lengths and feed units
1	DZ1230	For fitting under integral connectors

Pack	Cat. Nos.	Tap-off units
		Tap-off length is determined by the cable and not the conduit length, e.g. a 3 m tap-off has 3 m of cable and 2.6 m of flexible metal conduit <sup>1</sup> Tap-off units in excess of 3 m should only be used if they contain a fuse or if the busbar run is protected by a protective device not exceeding 32 A
		<b>32 A unfused - 543-7 high integrity</b>
		20 mm Ø, L, N, PE (4 mm <sup>2</sup> )
1	YP5332R	3 m
1	YP5532R	5 m
		<b>13 A fused - 543-7 high integrity</b>
		20 mm Ø, L, N, PE (4 mm <sup>2</sup> )
1	YP5314R	3 m
1	YP5514R	5 m

<sup>1</sup> : Tap-offs are supplied as standard with flexible metal conduit  
 For alternative wiring solutions, contact us on +44 (0) 370 608 9020

# Electrak® powertrack / underfloor busbar system

## design and installation

### General installation notes

Electrak powertrack is a compact system that can be installed in floor voids as low as 48 mm

Feed units are provided with one or two 25 mm diameter holes suitable for MICCC, armoured cables or single core cables in conduit  
Track lengths connect together and to feed units using the integral connectors on each length

Lengths should always be secured using the integral floor fixing brackets ; three on the 3.6 m length and two on 2.4 m, 1.8 m or 1.2 m lengths

Access to power is provided along the busbar length by simply plugging tap-off units into shuttered socket outlets. These tap-off units feed all types of conventional floor service outlet boxes or feed workstations directly through the floor via insulated conductors contained in flexible metal or VO rated nylon conduit. When connecting tap-offs directly through the floor via grommet outlets to workstations care must be taken to ensure that the tap-off length is adequate

The dual system has both standard and low noise / clean earth systems incorporated. As well as dual tap-offs, both standard and low noise / clean earth tap-offs can be plugged into any socket outlet along the busbar length. The dual tap-off incorporates both standard and low noise cables

Optimum layout flexibility is achieved by positioning busbar lengths a maximum of 5.2 m apart and 2.5 m from the wall, and by connecting the 3 m tap-off units to floor outlet boxes. This means every part of the floor area can be served. Flexible interlinks can be used to overcome obstructions or used as corners if required

### Dimensions

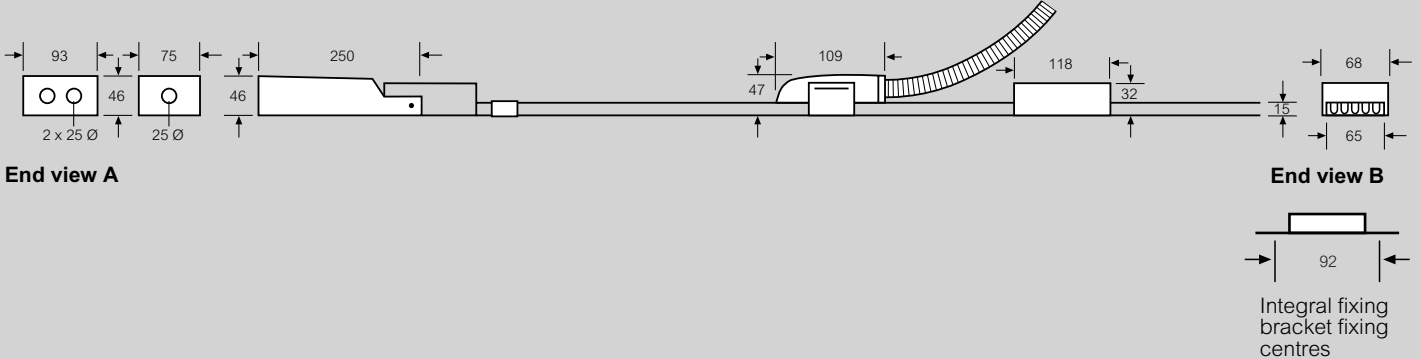

### Example floor layout

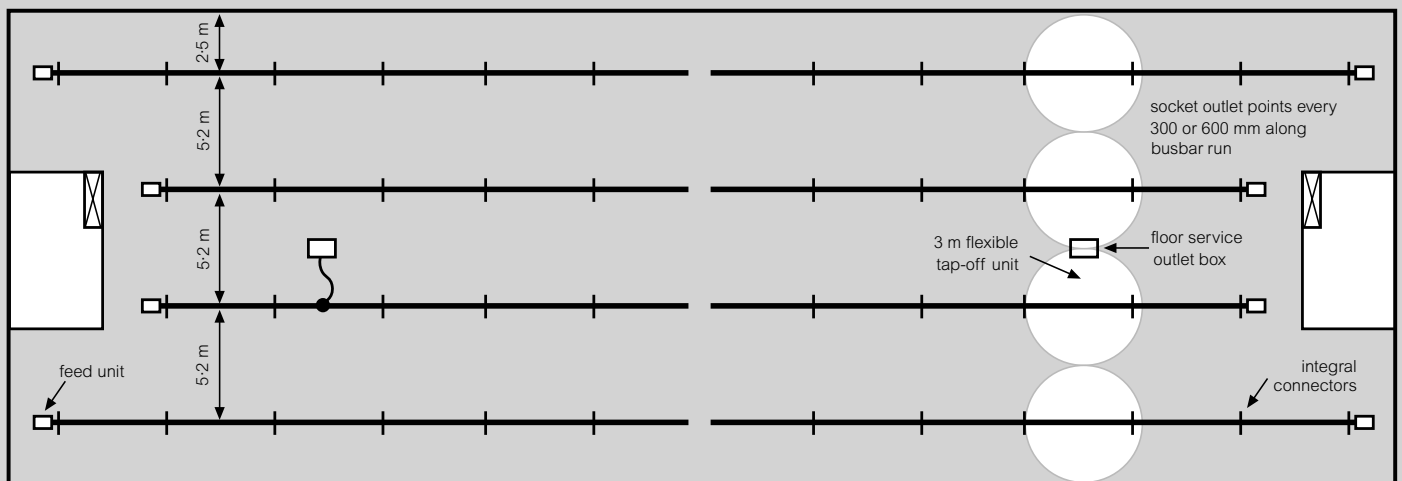

All dimensions (mm) are nominal

### Special fixing brackets

Electrak special fixing brackets are available to raise the system by 21 mm. Ensure brackets are spaced 600 mm apart and always have support under the integral connectors and feed units. Failure to do so may undermine the integrity of the system

Cat. No. DZ1210 raised off-floor fixing brackets are spaced at 600 mm centres along the busbar run. Also use bottom half of bracket under feed unit and flexible interlink

Cat. No. DZ1230 raised off-floor fixing brackets are always used under integral connectors. Busbar is secured to raised brackets using the integral fixing bracket

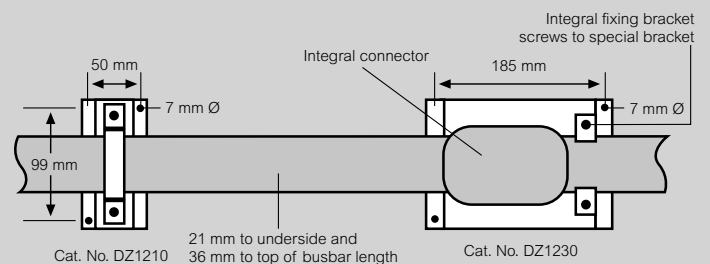

■ **Product configuration**

**Flexible interlink**

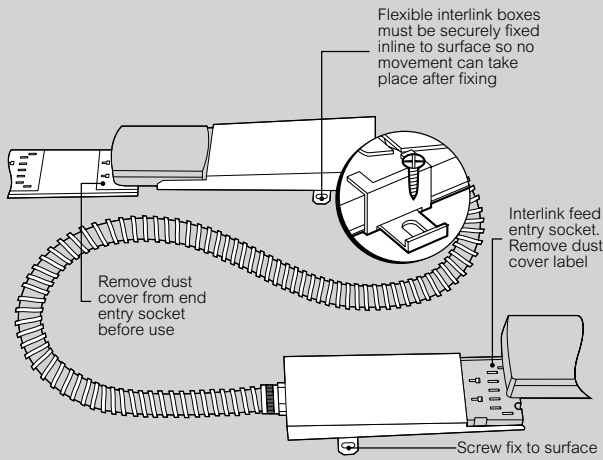

**Tap-off connection**

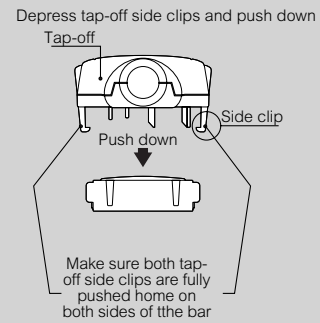

**Feed unit (Cat. No. DF1010) Sub-cabling**

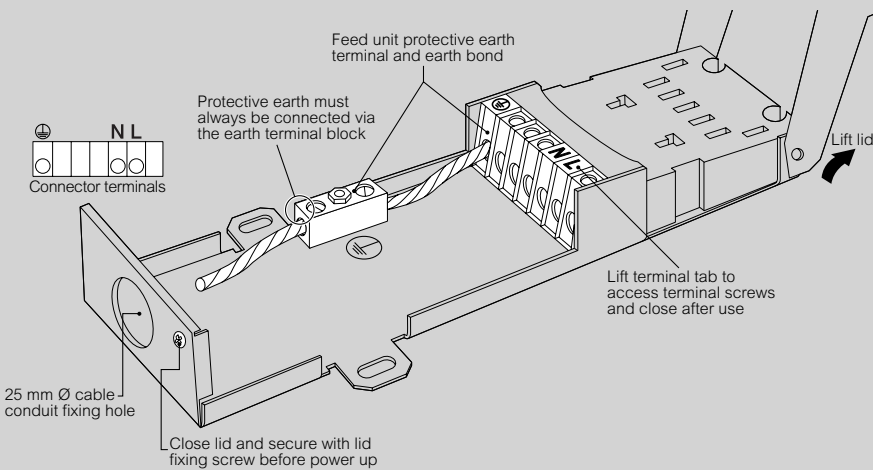

**Tap-off connection**

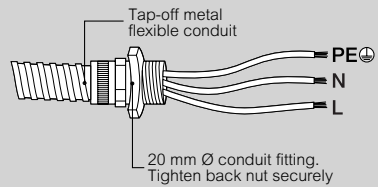

**Feed unit (Cat. No. JF2010 and JF2010R) Sub-cabling**

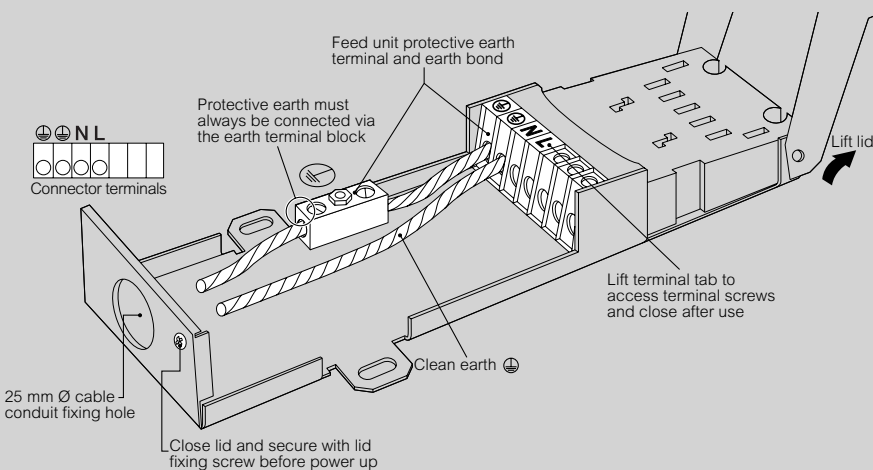

**Tap-off connection**

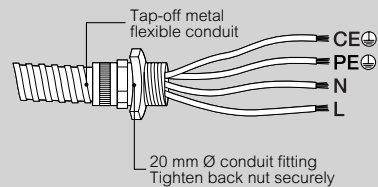

All dimensions (mm) are nominal

# Electrak® powertrack / underfloor busbar system

## design and installation (continued)

### Feed unit (Cat. No. KF3010) Sub-cabling

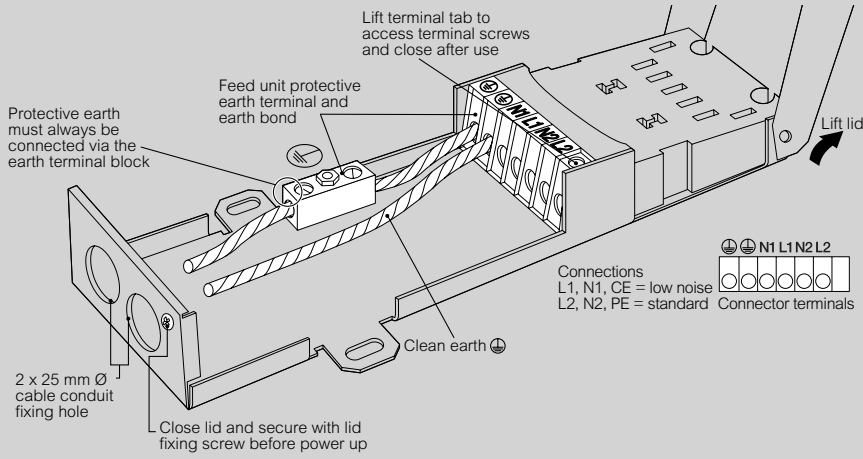

### Dual tap-off connection (dark green)

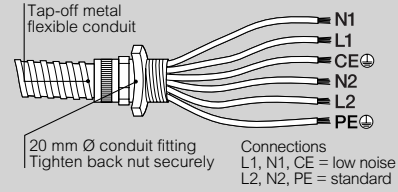

### Feed unit (Cat. No. NF4010) Sub-cabling

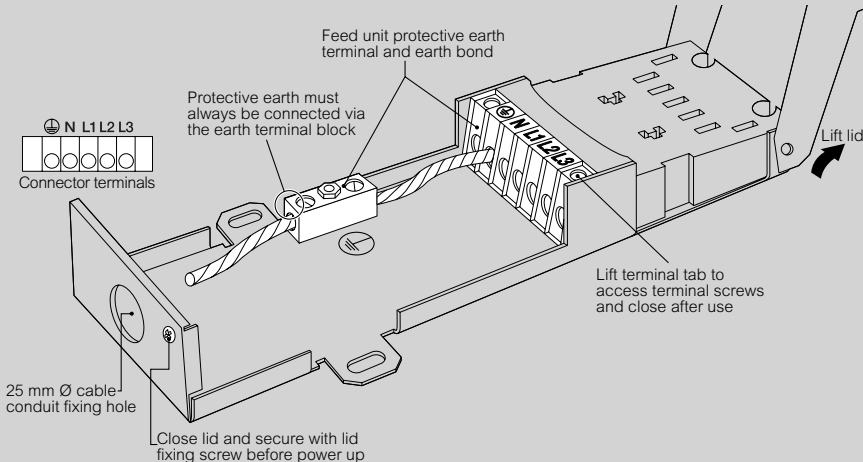

### 3 phase tap-off connection

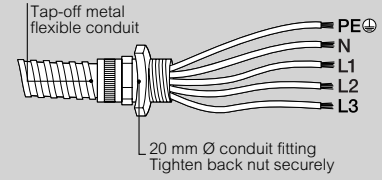

### Feed unit (Cat. No. YF5010 and YF5010R) Sub-cabling

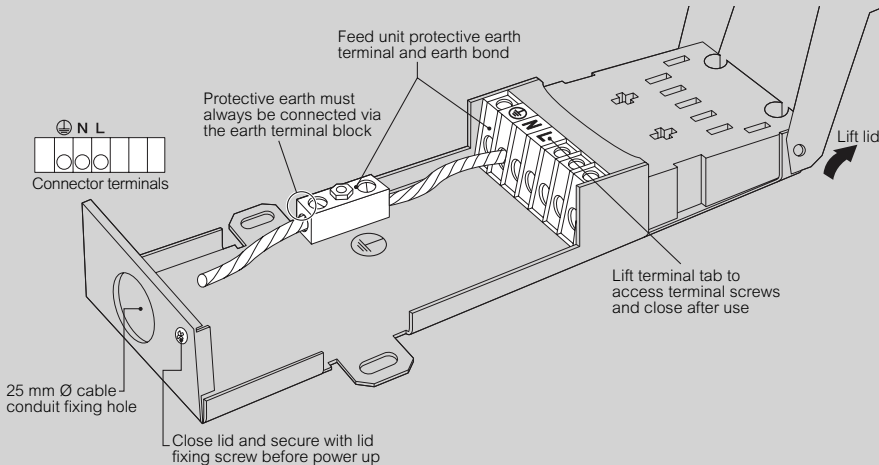

### Tap-off connection

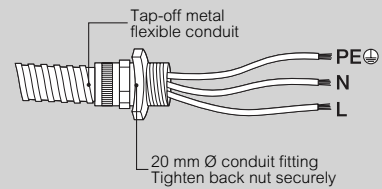

All dimensions (mm) are nominal

# Electrak® powertrack / underfloor busbar system

installation (continued)

## 1 Fix feed unit to surface

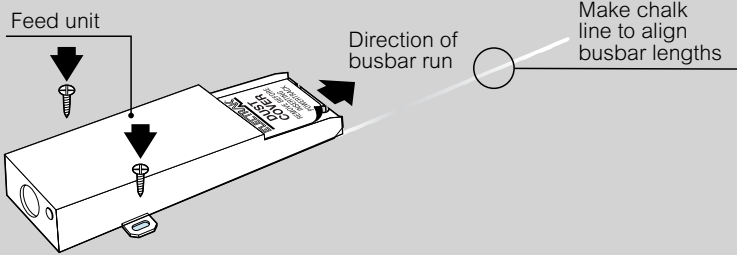

All integral fixing brackets must be fixed to surface at 1.2 m fixing centres from first bracket on each busbar length

## 2 Connect busbar length to feed unit

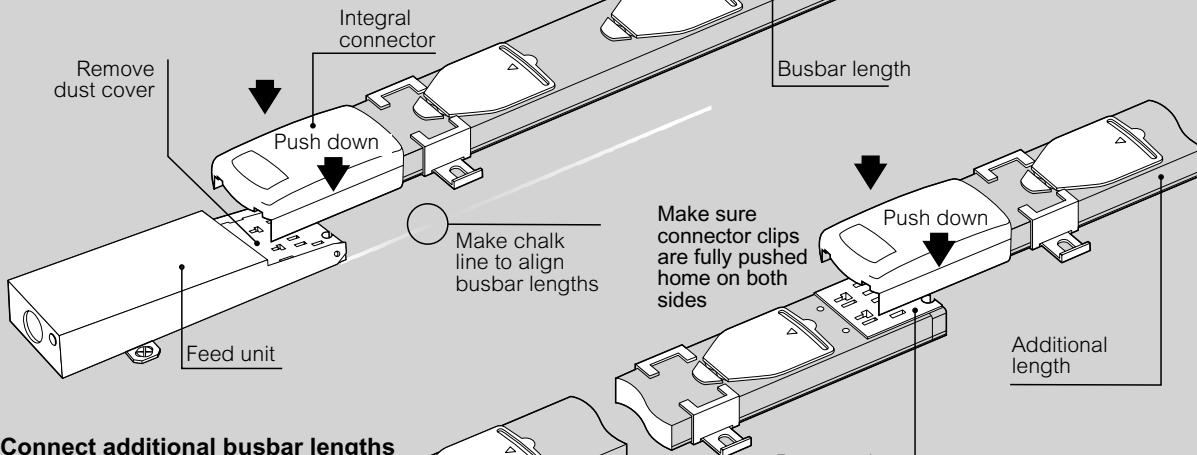

## 3 Connect additional busbar lengths

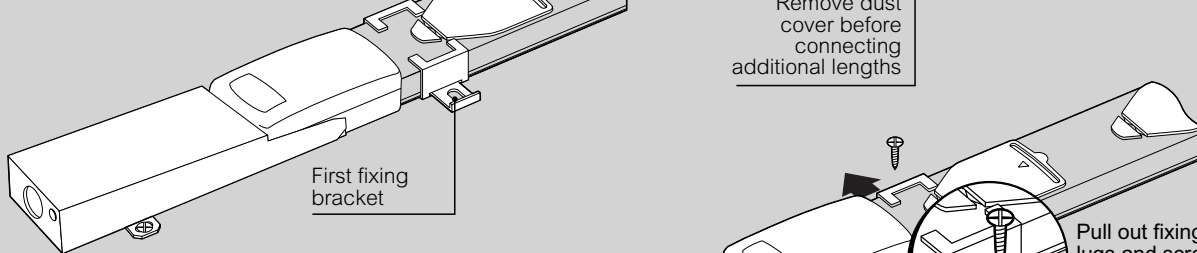

## 4 Secure busbar lengths to surface

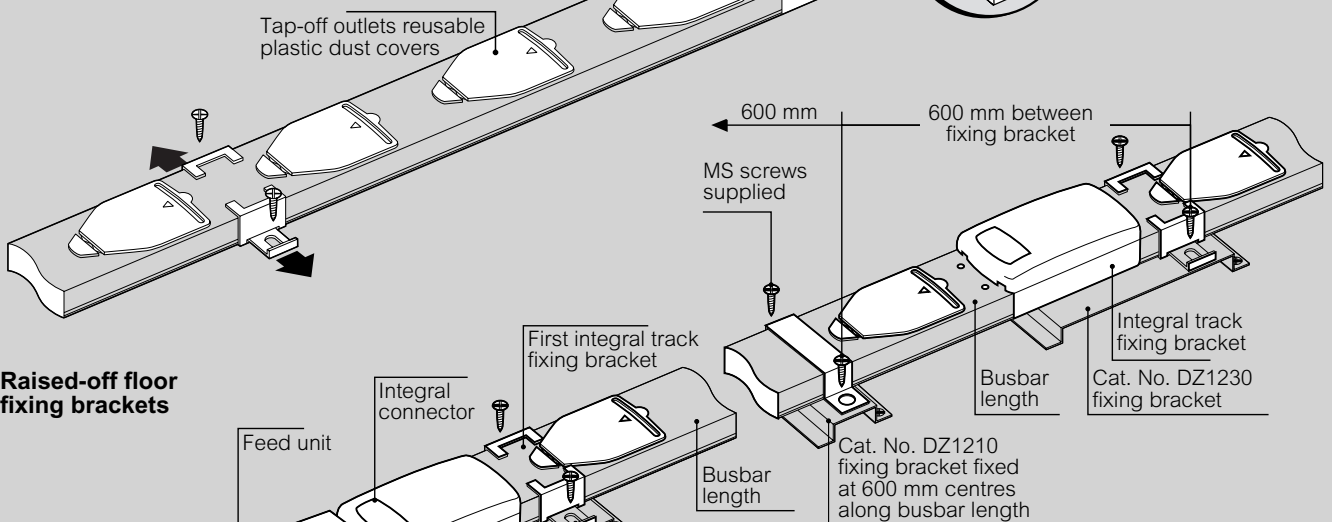

## 5 Raised-off floor fixing brackets

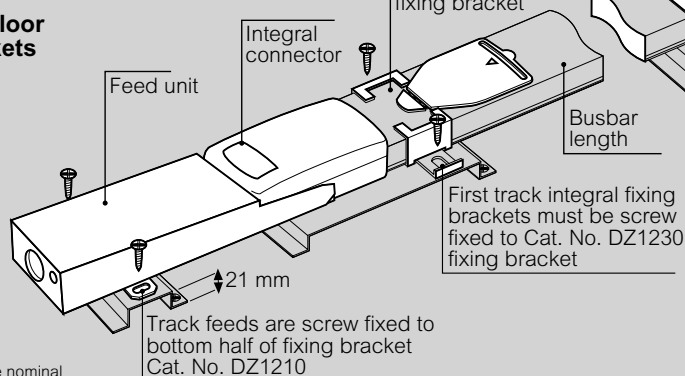

### Bracket fixing dimensions to surface

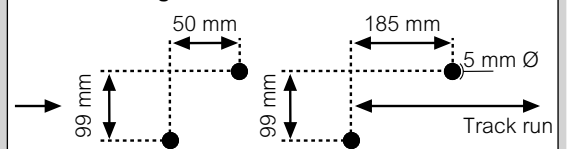

All dimensions (mm) are nominal



### Standards



BS EN 61534-22  
and IEC 61534-22  
Manufactured within an approved ISO 9001 and ISO 14001 facility  
Assessed Quality Assurance Certificate No. 2029  
Electrak powertrack / underfloor busbar fully complies with the  
requirements of BS 7671

### Classifications according to BS 61534-22

<b>7.1</b>	Resistance to impact	Medium impact – 5J
<b>7.2.2</b>	Connection	Tap-off is intended to be connected/disconnected when the system is energised but without a load connected
<b>7.3</b>	Degree of protection	IP40
<b>7.4</b>	Degree of pollution	Pollution degree 2
<b>7.5</b>	Rated impulse withstand voltage	Category III - 4kV
<b>7.101</b>	Type of floor treatment	Dry treatment of floor
<b>7.102</b>	Intended location	Underfloor powertrack system

### Ambient temperature rating factors

The current carrying capacity for a powertrack / underfloor busbar ( $I_n$ ) is affected by the ambient temperature  
For Electrak powertrack / underfloor busbar the ambient rating factor  $K_\alpha$  is equal to 1 for ambient temperatures up to and including 35° C

$$I_z = K_\alpha I_n$$

Where :

$I_z$  = effective current carrying capacity for continuous service under particular installation conditions

$K_\alpha$  = ambient temperature factor

$I_n$  = nominal current carrying capacity

For ambient temperatures exceeding 35° C the values of  $K_\alpha$  and  $I_z$  are given in the following tables

Powertrack / underfloor busbar system							
Ambient	20°C	25°C	30°C	35°C	40°C	45°C	50°C
<b><math>K_\alpha</math></b>	1			0.95	0.85	0.80	
<b><math>I_z</math></b>	63 A			59 A	53 A	50 A	

32 A unfused tap-off (using thermosetting 90°C cables)							
Ambient	20°C	25°C	30°C	35°C	40°C	45°C	50°C
<b><math>K_\alpha</math></b>	1			0.95	0.85	0.80	
<b><math>I_z</math></b>	32 A			30 A	27 A	25 A	

13 A fused tap-off (using 2.5 mm <sup>2</sup> thermosetting 90°C cables)							
Ambient	20°C	25°C	30°C	35°C	40°C	45°C	50°C
<b><math>K_\alpha</math></b>	1						
<b><math>I_z</math></b>	13 A						

### References :

BS 7671

### Earth fault loop impedance

BS 7671 requires accurate determination of the total earth loop impedance, which must be sufficiently low to allow the protective device to operate within the specified time, which for socket outlets is 0.4 seconds. The values relevant to Electrak powertrack / underfloor busbar for calculating the earth fault loop impedance are shown in the electrical test data table, see opposite

### Durability

Electrak systems are superbly designed and extremely robust. They can be expected to stand up to all normal site conditions. Electrak powertrack / underfloor busbar has been short circuit strength tested

### Installations with high protective conductor currents

All unfused tap-offs comply with Regulation 543.7 without the need for additional earth conductors. Regulation 543.7.1.203 (ii) states "a single copper protective conductor having a cross-sectional area of not less than 4 mm<sup>2</sup>, complying with the requirements of Regulations 543.2 and 543.3, the protective conductor being enclosed to provide additional protection against mechanical damage, for example, within a flexible conduit"

For installations with high protective conductor currents requiring fused tap-offs, a 543.7 compliant tap-off must be used. Normally fused tap-offs incorporate 1.5 mm<sup>2</sup> conductors, however in our fused 543.7 tap-offs, the 1.5 mm<sup>2</sup> earth conductor is replaced with a 4 mm<sup>2</sup> conductor and are therefore compliant with Section 543.7.1.203 (ii)

### 32 A tap-off unit

The 3 m 32 A tap-off unit comprises an unfused tap-off with 2.6 m of flexible metal conduit with integral 4 mm<sup>2</sup> LSOH conductors

These units are designed to comply with Regulation 543.7.1.203 (ii) of the IET Wiring Regulations by virtue of the following :

- maximum length of cable is 3 m
- it is factory assembled and fully tested item with cable installed in high quality flexible conduit

Fault condition protection for the tap-off assembly and the floor box socket outlets is delivered by the circuit protection device

Disconnection time for socket outlets is 0.4 seconds (Regulation 411.3.2.2). The Electrak system meets this requirement

Tap-off units in excess of 3 m should only be used if they contain a fuse or the busbar run is protected by a protective device not exceeding 32 A

#### Volt drops (live and neutral)

Busbars	3.0 mV/A/m
Cable connector	0.4 mV/A
Integral connector	0.4 mV/A
32 A tap-off	0.4 mV/A
+ 4 mm <sup>2</sup> cable	11 mV/A/m
Flexible corner assembly	1.5 mV/A
+ 10 mm <sup>2</sup> cable	4.0 mV/A/m

#### Earth fault loop impedance

Phase busbar	1.5 mΩ/m
Earth busbar	1.5 mΩ/m
Earth housing	1.1 mΩ/m
Earth busbar and housing	0.8 mΩ/m
Cable connector	0.4 mΩ
Integral connector	0.6 mΩ
32 A tap-off	0.6 mΩ
+ 4 mm <sup>2</sup> cable	11 mΩ/m
Flexible corner assembly	1.5 mΩ
+ 10 mm <sup>2</sup> cable	4.0 mΩ/m
Rated conditional short-circuit current	16 KA
Ambient temperature	25°C

#### Mechanical data

	E24 – E28	E28R
Number of conductors	3-6	3
Busbar conductor cross sectional area	13 mm <sup>2</sup>	13 mm <sup>2</sup>
Housing cross sectional area (copper equivalent)	13 mm <sup>2</sup>	13 mm <sup>2</sup>
Cable terminal capacity	16 mm <sup>2</sup>	16 mm <sup>2</sup>
Tap-off cable 32 A	4 mm <sup>2</sup>	4 mm <sup>2</sup>
Tap-off cable 13 A fused	1.5 mm <sup>2</sup>	2.5 mm <sup>2</sup>
Tap-off conduit, up to 4 conductors	16 mmØ	20 mmØ
Tap-off conduit, 5 and 6 conductors	20 mm <sup>2</sup>	N/A
Flexible corner cable (tri-rated, high temperature)	10 mm <sup>2</sup>	10 mm <sup>2</sup>
Flexible corner conduit	25 mmØ	25 mmØ
IP rating	40	40

#### Electrical test data

Rated current	63 A
Rated voltage	230/400 V~
Frequency	50 Hz
Conductor resistance - live and neutral	3.0 mΩ/m
Conductor impedance	1.5 mΩ/m

#### Material specifications

Housing - busbar lengths	Galvanised steel, natural finish
Busbars	High conductivity copper (Tinned version is electro-tin plated)
Busbar insulator	PTFE
Integral connectors / Tap-off outlets	Flame retardant polycarbonate
Tap-off outlet entry shutter	Acetal
Tap-off housing	Flame retardant polycarbonate
Integral connector blades	Copper (Tinned version is plated)
Tap-off blades	Copper (Tinned version is plated)
Tap-off/flexible corner conduit, metal	Electro-galvanised steel
Tap-off cable	LSOH to BS EN 50525
Flexible interlink cable	Tri-rated to BS 6231
Feed box/flexible interlink boxes	Galvanised steel
Feed connector terminals/earth block	Brass (Tinned version is plated)
Fixing brackets	Galvanised steel
13 A tap-off, fuse	To BS 1362